

HOW TO ORDER KEMET/EVOX CAPACITORS

The **Evox** article code includes all the information needed to specify the product characteristics and type of packing. This article code construction applies for the following products in this catalogue: **MMK**, **SMR** and **PFR**.

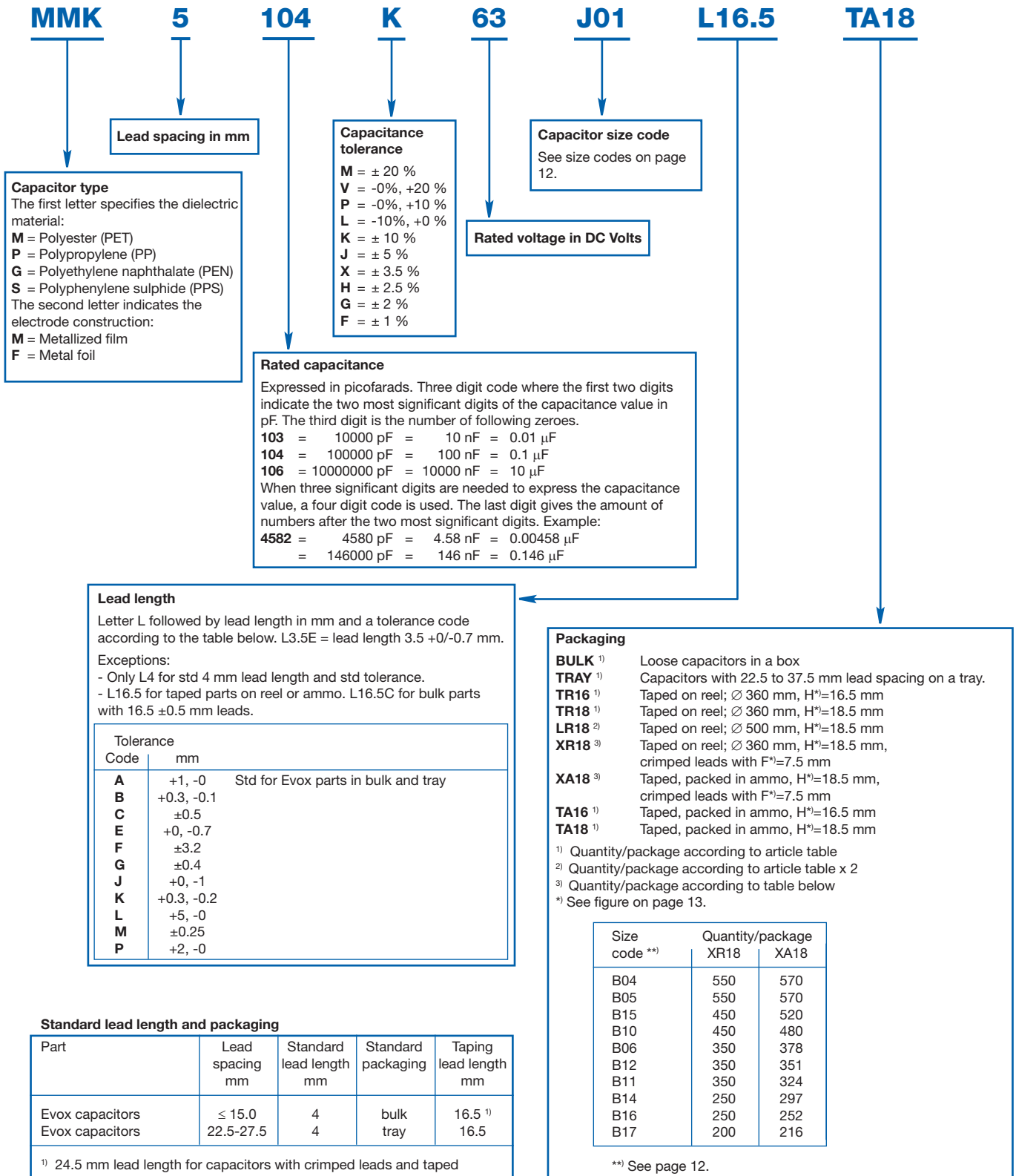

HOW TO ORDER KEMET/RIFA CAPACITORS

The **Rifa** article code includes all the information needed to specify the product characteristics and type of packing. This article code construction applies for the following products in this catalogue: **PHE820, PHE840E, PHE840M, PHE841, PHE844, PHE845, PHE850, PME261, PME264, PME271, PME278, PME295, PZB300, PMZ2074, PHZ9004, PMR205, PMR209, PMR210, PMZ2035, PHE426, PHE429, PHE448, PHE450.**

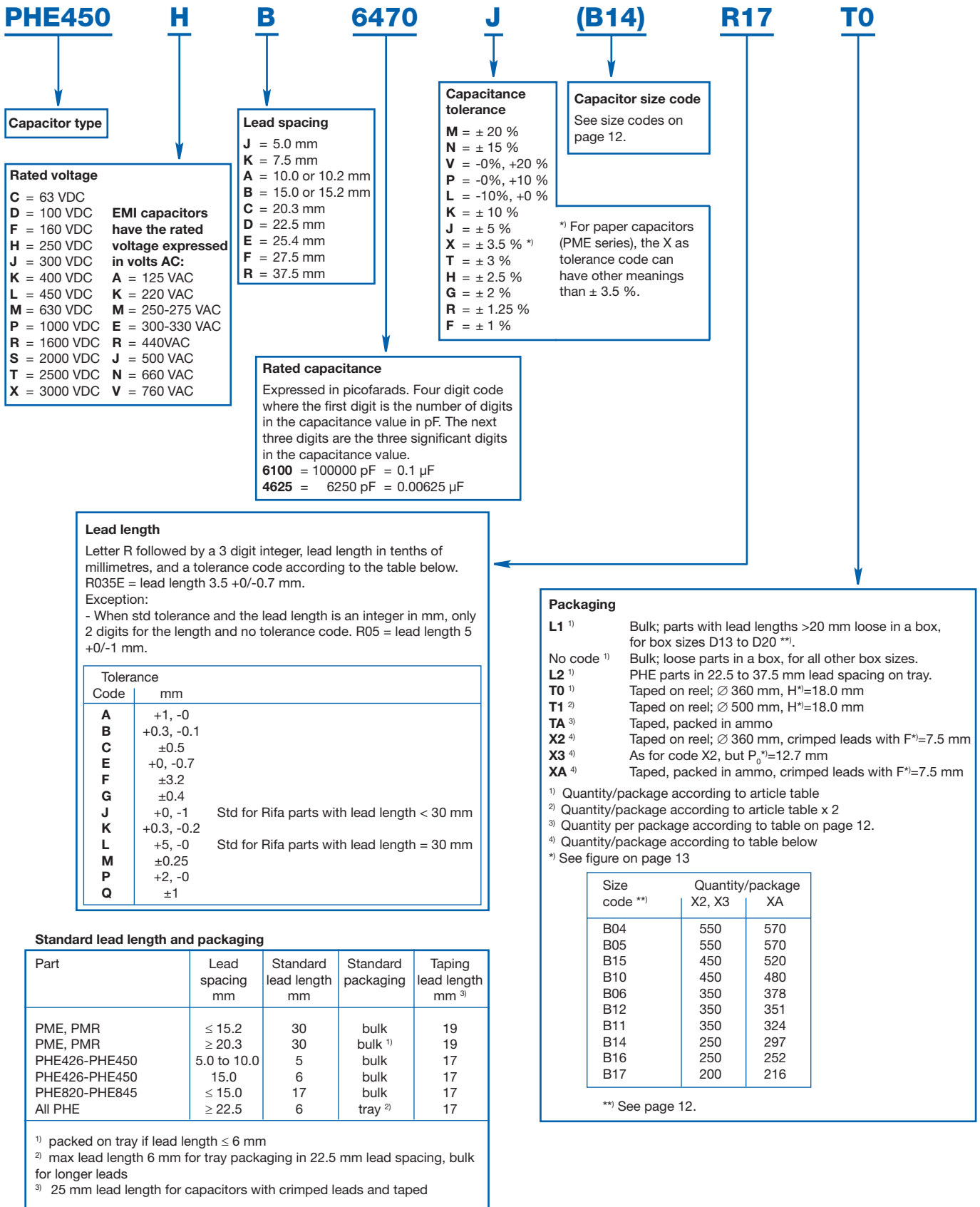

SIZE CODES OF LEADED CAPACITORS

A size code has been added to the following leaded Evox Rifa capacitors: **MMK, SMR, PHE840E, PHE840M, PHE850, PFR**. The size code determines the size of the component and the packing quantities. The size codes are as follows:

Size code in Article Code	Box dimensions in mm				Typical weight ¹⁾ g	Quantity per package			Reel Ø360	Reel Ø500	Ammo ³⁾
	B _{max}	H _{max}	L _{max}	p		Bulk ¹⁾	Bulk ²⁾	Tray			
A01	4.0	9.0	13.0	10.0	0.6	1000	1000		900	1800	
A02	4.5	10.5	13.0	10.0	0.9	1000	1000		800	1600	
A03	5.0	11.0	13.0	10.0	1.0	800	800		700	1400	
A04	6.0	12.0	13.0	10.0	1.3	600	600		500	1000	
A05	9.5	7.5	13.0	10.0	1.2	600	600		350	700	
A06	4.0	8.0	13.0	10.0	0.5	1000	1000		900	1800	
B04	5.5	10.5	18.0	15.0	1.5	1000	800		600	1200	
B05	5.5	12.5	18.0	15.0	1.7	1000	800		600	1200	
B06	7.5	14.5	18.0	15.0	2.7	800	400		400	800	
B10	6.5	12.5	18.0	15.0	2.0	1000	600		500	1000	
B11	8.5	16.0	18.0	15.0	3.4	600	400		400	800	
B12	8.0	15.0	18.0	15.0	3.0	600	400		400	800	
B14	9.5	17.5	18.0	15.0	4.2	500	300		350	700	
B15	6.0	12.0	18.0	15.0	1.7	1000	800		500	1000	
B16	11.0	19.0	18.0	15.0	4.4	350	250		300	600	
B17	13.0	12.5	18.0	15.0	3.4	400	300		250	500	
D13	6.5	14.5	26.0	22.5	2.7		450 ⁴⁾	234	300	600	
D14	8.0	16.0	26.0	22.5	3.8		350 ⁴⁾	186	250	500	
D15	9.0	18.5	26.0	22.5	5.0		250 ⁴⁾	308	250	500	
D16	11.0	21.5	26.0	22.5	6.6		200 ⁴⁾	253			
D17	7.0	16.5	26.0	22.5	3.2		350 ⁴⁾	216	300	600	
D18	10.5	19.0	26.0	22.5	5.8		250 ⁴⁾	264			
D19	15.5	24.5	26.0	22.5	10.0		125 ⁴⁾	176			
D20	13.5	23.0	26.0	22.5	8.2		150 ⁴⁾	209			
F03	13.5	23.0	31.5	27.5	10.8			171			
F11	10.5	20.5	31.5	27.5	8.0			216			
F12	11.5	22.5	31.5	27.5	9.1			198			
F13	14.5	24.5	31.5	27.5	14.5			153			
F14	17.5	28.0	31.5	27.5	17.0			126			
F15	19.0	29.0	31.5	27.5	19.5			117			
F16	21.0	30.0	31.5	27.5	22.6			108			
F17	21.0	12.5	31.5	27.5	9.0			108			
F18	31.0	19.0	31.5	27.5	20.0			72			
F19	27.5	16.0	31.5	27.5	17.0			81			
J01	2.5	6.5	7.2	5.0	0.2	2000	2000		2500	5000	3000
J02	3.5	8.0	7.2	5.0	0.3	2000	2000		2000	4000	2000
J03	4.5	9.0	7.2	5.0	0.4	1000	1000		1500	3000	1700
J04	5.0	10.0	7.2	5.0	0.5	1000	1000		1300	2600	1500
J05	6.0	11.0	7.2	5.0	0.6	1000	1000		1000	2000	1200
J06	7.2	13.0	7.2	5.0	0.9	1000	1000		800	1600	
J11	4.5	6.0	7.2	5.0	0.3	1000			1500	3000	1700
J12	5.5	7.0	7.2	5.0	0.4	1000			1200	2400	1300
J13	6.5	8.0	7.2	5.0	0.5	1000			900	1800	1100
K00	2.5	6.0	10.0	7.5	0.3	2000	2000		2500	5000	3000
K01	4.0	8.0	10.0	7.5	0.5	1000	1000		1700	3400	1900
K03	5.0	11.0	10.0	7.5	0.8	1000	1000		1300	2600	1500
K04	6.0	12.0	10.5	7.5	1.0	1000	1000		1000	2000	1200
R02	16.5	32.0	41.0	37.5	23.0				105		
R03	19.0	36.0	41.0	37.5	28.5				91		
R04	15.0	26.0	41.0	37.5	17.0				119		
R05	13.0	24.0	41.0	37.5	14.0				140		
R06	21.0	38.0	41.0	37.5	34.4				84		
R08	28.0	43.0	41.0	37.5	53.0				63 ¹⁾		

¹⁾ Capacitors with lead length of 4 to 6 mm according to the data sheet.

²⁾ Capacitors with lead length of 16.5 mm or 17.0 mm according to the data sheet.

³⁾ For Ammo packaging of parts in 10 mm and 15 mm lead spacing, please ask KEMET Customer Service.

⁴⁾ Capacitors with lead length of > 20 mm.

TAPING OF KEMET RADIAL CAPACITORS

The taping is carried out in accordance with IEC 60286-2.

Lead spacing 5 mm

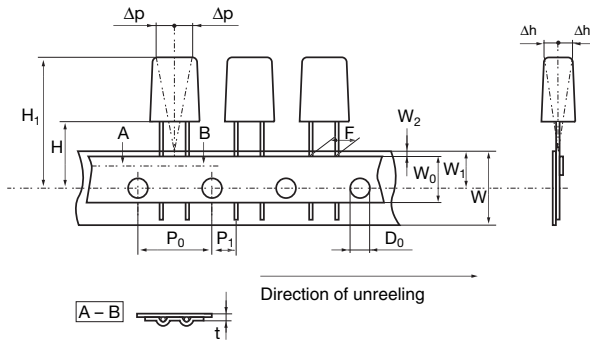

Lead spacing 7.5 mm

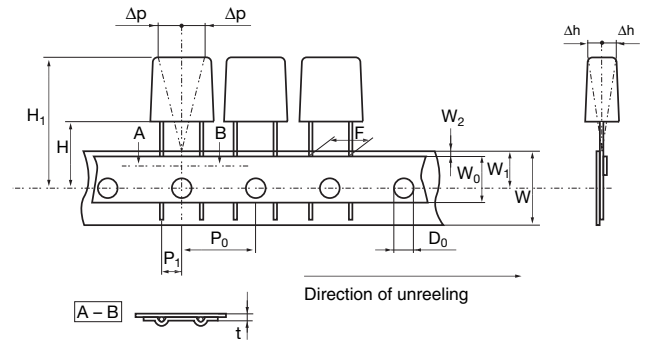

Lead spacing 10 and 15 mm

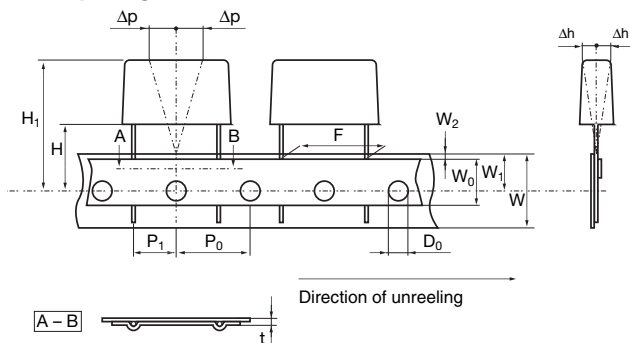

Lead spacing 22.5 and 27.5 mm

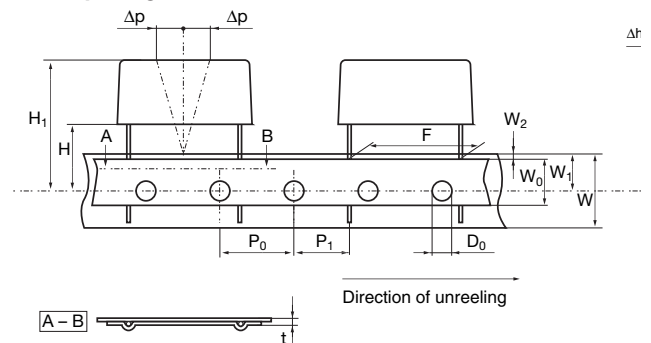

Crimped leads

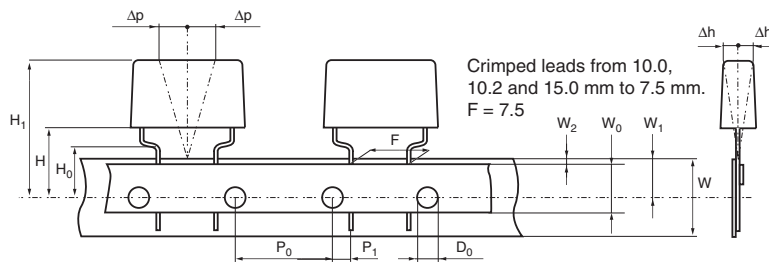

Taping specification							Standard
Dimensions in mm							IEC 60286-2
Lead spacing, $^{+0.6}_{-0.1}$	F	5.0/7.5	7.5 $^{+0.6}_{-0.1}$	10.0/15.0	22.5/27.5	10.2/15.2/20.3	F
			Crimped leads			Paper capacitors	
Carrier tape width, ± 0.5	W	18	18	18	18	18	18 $^{+1.0}_{-0.5}$
Hold-down tape width, ± 0.3	W ₀	9	12	12	12	12	
Position of sprocket hole, ± 0.5	W ₁	9	9	9	9	9	9 $^{+0.75}_{-0.5}$
Distance between tapes, max	W ₂	3	3	3	3	3	3
Sprocket hole diameter, ± 0.2	D ₀	4	4	4	4	4	4
Feed hole pitch, ± 0.3	P ₀ ¹⁾	12.7	15/12.7	12.7	12.7	12.7	12.7/15
Distance lead – feed hole, ± 0.7	P ₁	3.85/3.75	3.75	7.7/5.2	5.3	7.6/5.1/8.9	P ₁
Max deviation tape – plane	Δp	1.3	1.3	1.3	1.3	1.3	1.3
Max lateral deviation	Δh	2	2	2	2	2	2
Total thickness, ± 0.2	t	0.7	0.7	0.7	0.9 max	0.7	0.9 max
Sprocket hole/cap body	H ²⁾	18.5 ±0.5		18.5 ±0.5	18.5 ±0.5	18.0 $^{+2}_{-0}$	18.0 $^{+2}_{-0}$
		16.5 ±0.5		16.5 ±0.5			
Sprocket hole/crimped leads	H ₀ ²⁾		16 ±0.5				16 ±0.5
			18 ±0.5				
Sprocket hole/top of cap body, max	H ₁ ³⁾	32/31 max	40 max	43 max	58	35 max	58 max

1) Cumulative pitch error
 2) Alternatives for different insertion machines
 3) Depending on case size
 4) Crimped leads available on request

GENERAL INFORMATION

TAPING OF KEMET RADIAL CAPACITORS

Reel specification			
Reel dimensions in mm		Tol.	
Reel diameter	A	360/500	max
Hub diameter	N	80	min
Arbor hole	C	30	± 1
Total reel width measured at hub	W2	58	max

The standard packing for lead space ≤ 15 mm is 360 mm reel and for lead space > 15 mm 500 mm reel.

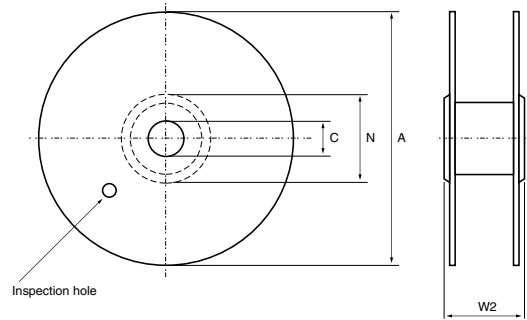

Ammo pack specification			
Ammo pack dimensions in mm		Lead spacing, mm 5, 7.5 10 15, 22.5, 27.5, 37.5	
Height	H	330	(135 or 200 for CQ depending on capacitance value)
Width	W	330	(335 for CQ)
Thickness	T	50	

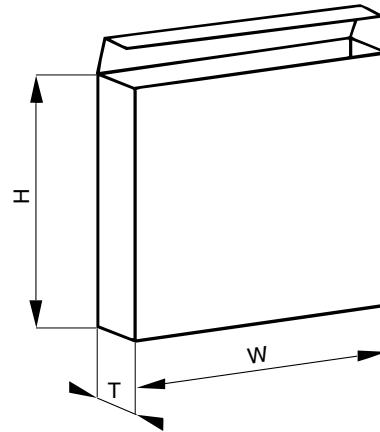

THE MANUFACTURING CODE Y Z, ACCORDING TO IEC 60062

where Y = year, Z = month.

Year	Code	Year	Code	Year	Code	Month	Code	Month	Code
1991	B	2001	N	2011	B	Jan	1	July	7
1992	C	2002	P	2012	C	Febr	2	Aug	8
1993	D	2003	R	2013	D	March	3	Sept	9
1994	E	2004	S	2014	E	April	4	Oct	O
1995	F	2005	T	2015	F	May	5	Nov	N
1996	H	2006	U	2016	H	June	6	Dec	D
1997	J	2007	V	2017	J				
1998	K	2008	W	2018	K				
1999	L	2009	X	2019	L				
2000	M	2010	A	2020	M				

TERMS AND DEFINITIONS

Rated capacitance (C_r)

The rated capacitance of a capacitor is the value which is indicated upon it. The capacitance is measured at 1 kHz and +23°C.

Rated voltage (U_r)

The rated voltage is the maximum direct voltage or the maximum RMS alternating voltage which may be applied continuously to the terminals of the capacitor at any temperature within the rated temperature range.

Rated temperature

The rated temperature is the maximum ambient temperature at which the rated voltage can be continuously applied.

Climatic category

The climatic category states the category temperature range and the humidity class. For example 40/085/56 stands for -40°C to +85°C; 56 states that the steady state humidity test should take 56 days.

Tangent of the loss angle (Dissipation factor, $\tan\delta$)

The tangent of the loss angle is the power loss of the capacitor divided by the reactive power of the capacitor at a sinusoidal voltage of specified frequency. The tangent of loss angle is given in percent (Eg 0.01 $\tan\delta=1\%$). The dissipation factor is of interest especially when the capacitor is operated on AC. The dielectric loss causes heating of the capacitor which under unfavourable circumstances may lead to a destructive breakdown. This will not happen if the capacitor is used within specified limits. The ability to withstand short duration thermal and voltage overload is greater for small capacitors than for large ones.

Insulation resistance

The values given in the catalogue indicate the insulation resistance after one minute of electrification at +23°C with the following voltages: 100 VDC for capacitors rated at 100 to 500 VDC and 500 VDC for capacitors rated at 500 VDC. Insulation resistance is temperature dependent and is approximately halved for each 7 °C of temperature rise. Multilayer construction provides insulation resistance higher than that of single-layer types.

Temperature derated voltage

For any temperature between the rated temperature and the upper category temperature, the temperature derated voltage is the maximum voltage that may be applied continuously to the terminals of the capacitor.

Pulse operation

Capacitors loaded with pulses with fast rise or fall times (high dU/dt) will be exposed to high current pulses. In order not to overload the internal connections the current must be limited. The current limits for a specific type are dependent upon:

- Amplitude and form of the pulse
- Rated voltage of the capacitor
- Capacitance
- Geometrical configuration of the winding

$$dU/dt = U_r / (R \times C)$$

U_r = Rated voltage

R = Discharge resistor

C = Rated capacitance

At repeated pulse operation, self-heating, ambient temperature and cooling set the load limit.

Pulse current limits are commonly expressed in the form of maximum permitted dU/dt in volts per microsecond. The figures stated in the type specifications refer to an unlimited number of pulses charging or discharging from rated voltage U_r .

Self-healing

A break-through in a plastic film/foil capacitor leads to a permanent short circuit of the capacitor due to a carbon bridge which is built up in the break-down channel due to the high temperature rise and carbon content of the dielectric. A metallized capacitor can withstand a break-through without a permanent short circuit because of its self-healing ability. The metallized layer is between 0.02 – 0.1 μm . At a weak point in the dielectric, or because of a transient, a break-down may occur. The thin metal layer around the weak point is evaporated and the weak point is isolated. The capacitor has self-healed thereby.

Active flammability

The ability of a capacitor to burn with a flame as a consequence of electrical loading.

Passive flammability

The ability of a capacitor to burn with a flame as a consequence of the application of an external source of heat.

Attenuation

The attenuation of a capacitor is measured in a 50 Ω system.

The highest attenuation is achieved at the resonant frequency.

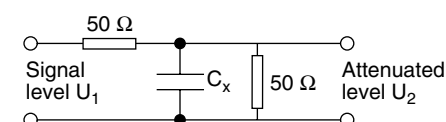

$$\text{Attenuation } a = 20 \log U_1 / 2U_2 \text{ dB}$$

Resonance frequency

The resonance frequency of a capacitor is reached when

$$\omega L = 1/\omega C$$

$$\omega = 2\pi f \text{ (f = frequency)}$$

L = inductance caused by the winding and the length of the leads

C = the capacitance at f.

Dielectric absorption (DA)

Dielectric absorption describes the dielectric material's properties to "remember" the applied voltage. One method to define DA is:

The capacitor is to be charged for one hour at rated voltage DC (U_r) then discharged through a resistor of 5 ohms for 10 seconds. The discharge resistor must then be disconnected and the recovery voltage U_r measured 15 minutes after disconnection. The dielectric absorption is defined by:

$$DA = (U_r / U_r) \times 100\%$$

More specific terms and definitions for EMI, RC and Pulse capacitors can be found in the beginning of respective sections.

CAPACITOR EQUIVALENT DIAGRAM

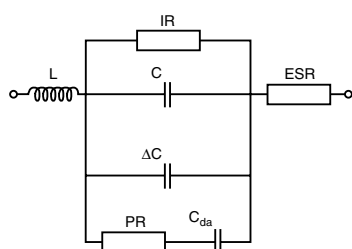

C = nominal value of the capacitor

L = inductance (leads, metallization, winding)

ESR = equivalent series resistance (leads, metallization, metal spraying)

IR = insulation resistance (properties of the dielectric material)

ΔC = capacitance change

(depending on changes in temperature, DC voltage and/or frequency)

PR = dielectric polarization resistance

C_{da} = dielectric absorption

PROPERTIES OF DIELECTRICS

**POLYESTER
(Polyethylene Terephthalate, PET)
Metallized and Film/foil**

High dielectric constant and high dielectric strength provides good volumetric efficiency for metallized polyester film capacitors. Metallized polyester film has excellent self-healing properties.
Typical applications: Bypassing, coupling, filtering.

**POLYESTER
(Polyethylene Naphthalate, PEN)
Metallized**

High temperature Polyester. Relatively high dielectric constant and dielectric strength, and availability of thin films, provide

good polymeric efficiency for metallized construction. High melting point allows SMD constructions and service in high ambient temperatures. General purpose capacitor.

**POLYPROPYLENE (PP)
Metallized and Film/foil**

Very low losses, low dielectric absorption, high dielectric strength, very high insulation resistance, and negative temperature coefficient.
Typical applications: Stable oscillators and filters. Sample & hold circuits, pulse handling circuits, AC applications and mains filtering.

**POLYPHENYLENE SULPHIDE (PPS)
Metallized**

Low losses, wide operating temperature range, low temperature coefficient, good stability.
Typical applications: Timers and filters. Automotive and other applications in high ambient temperatures.

**PAPER
Metallized**

High dielectric constant. Excellent self-healing properties and transient handling capability. High ionisation level due to impregnated dielectric material. Outstanding reliability in mains connected and other low frequency applications.

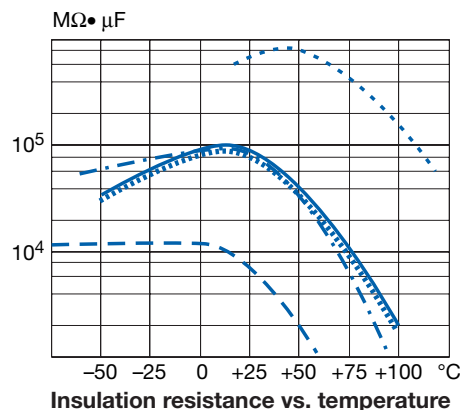
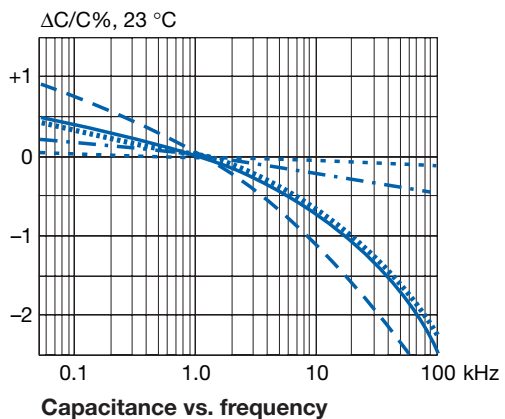
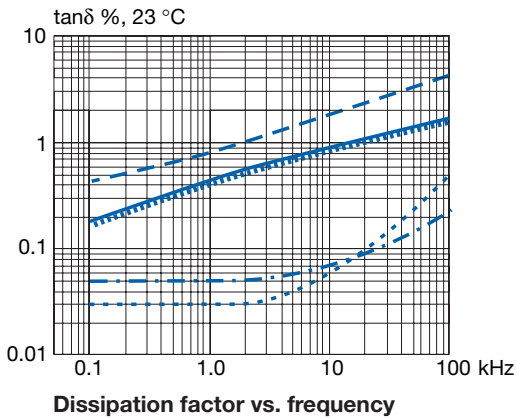
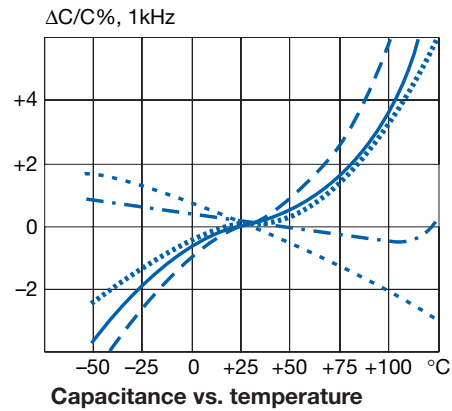
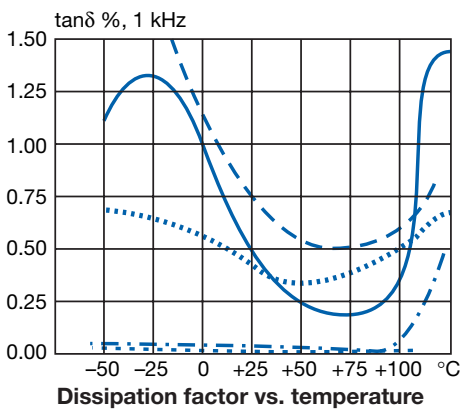

- Polyester PET
- Polyethylene Naphthalate PEN
- · - · Polyphenylene sulfide PPS
- Polypropylene PP
- Paper

RELIABILITY

The reliability of a capacitor is mainly a function of:

- The construction; dielectric material and its thickness
- The manufacturing process
- The application; electrical stress and temperature

The failure rate, λ , vs. voltage and temperature for the most common dielectric materials is shown in the diagrams below. U_R = rated voltage.

The operating life (L) can be calculated as:

$$L = \frac{1}{\lambda} \times \ln \frac{1}{1-F}$$

where F is the expected probability of failures.
 Example: If $\lambda = 20 \times 10^{-9}$ it takes 6 years to have
 F = 0.001 (0.1% failures) and 300 years to have
 F = 0.05 (5% failures)

MTBF (mean time between failures) = $1 / \lambda$

Failure rates vs. temperature and voltage Polyethylene Naphthalate (PEN)

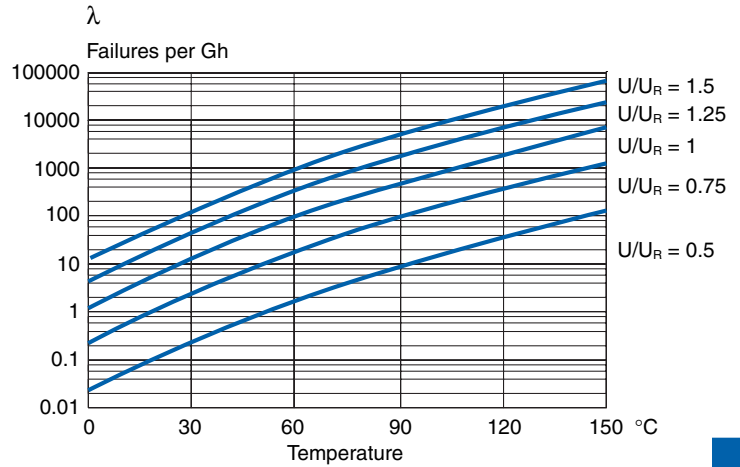

Failure rates vs. temperature and voltage Paper

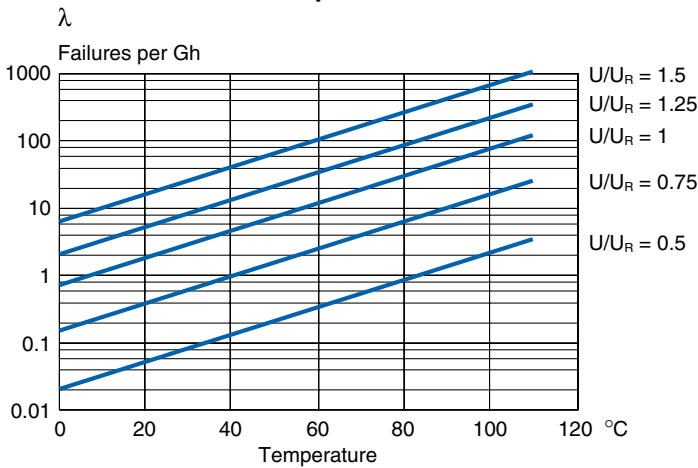

Failure rates vs. temperature and voltage Polyester

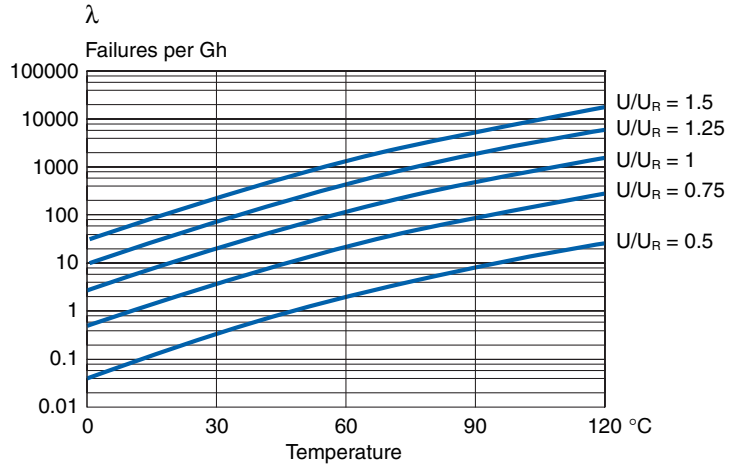

Failure rates vs. temperature and voltage Polypropylene

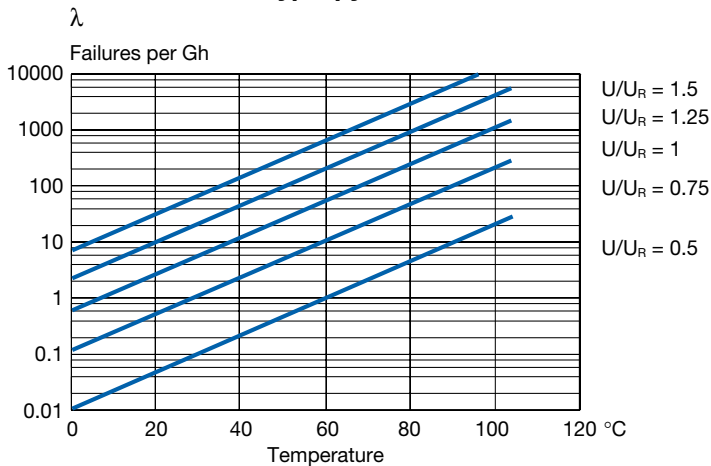

Failure rates vs. temperature and voltage Polyphenylene sulfide

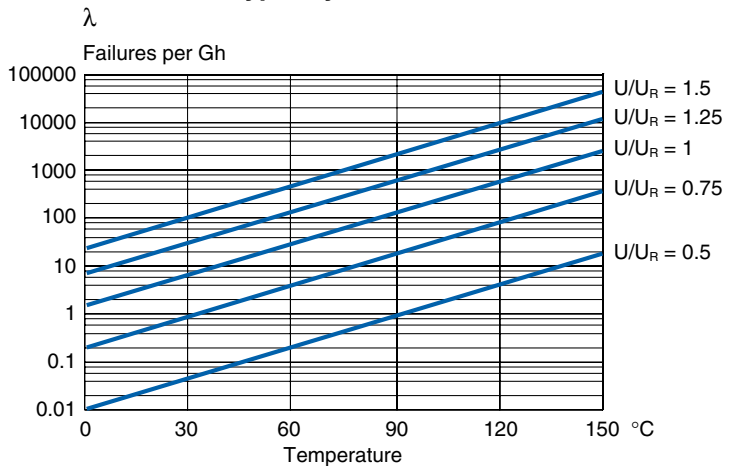

GENERAL INFORMATION

NUMERICAL COMPARISON OF FILM MATERIALS

Material (Trade names)	Abbreviation	Min. film thickness (μm)	Dielectric constant at 1 kHz, +23°C	Operating temperature (°C)	Temperature coefficient (ppm/°C)	Dissipation factor at 1 kHz, +23°C	Insulation time constant (s) at +23°C	Dielectric absorption %
Polyester (Mylar, Lumirror, Hostaphan, Diafoil)	PET	0.9	3.3	-55 ... +100 (... +125)	+400 (± 200)	0.5%	25 000	0.5
Polyethylene Naphthalate (Teonex)	PEN	1.4	3.0	-55 ... +125 (... +150)	+200 (± 150)	0.4%	25 000	1.2
Polyphenylene sulfide (Torelina)	PPS	1.2	3.0	-55 ... +125 (... +150)	0 (-50) -55°C to +100°C 550 (± 50) +100°C to +150°C 0 (+50) +150°C to +200°C	0.06%	25 000	0.05
Polypropylene (Torayfan, Trespaphan)	PP	3.0	2.2	-55 ... +110	-200 (-100, +50) almost linear	0.03%	100 000	0.01
Paper Impregnated	P	7.0	5.5	-40 ... +115	+1200 (± 200)	0.8%	15 000	

ENVIRONMENTAL COMMITMENT

As an environmentally conscious company, Evox Rifa (including BHC Components) is working continuously with improvements concerning the environmental effects of both our capacitors and the production of them.

In Europe (RoHS Directive) and in some other geographical areas like China, legislation has been put on place to prevent the use of some hazardous materials, like Lead (Pb), in electronic equipment. All products in this catalogue are produced to help our customer's obligations to guarantee their products to fulfil these legislative requirements. The only material of concern in our products has been Lead (Pb), which has been removed from all designs to fulfil the

requirement of containing less than 0,1% of Lead in any homogeneous material.

Evox Rifa will follow closely any changes in legislation world wide, and makes any necessary changes in its products, whenever needed.

Some customer segments like Medical, Military and Automotive Electronics may still require e.g. the use of Lead in electrode coatings. To clarify the situation, and to distinguish products from each other, a special symbol is used on the packaging labels for RoHS compatible capacitors. See pictures to the right.

Because of customer requirements there may appear additional markings like LF = Lead Free or LFW = Lead Free Wires on the label.



RoHS Compliant

Examples of RoHS Compliance markings on packaging labels

WARNING

The implementation of RoHS Directive has forced to select SnAuCu (SAC) alloys or SnCu alloys as primary solder. This has increased the liquidus temperature from that of 183 °C for SnPb eutectic alloy to 217 – 221 °C for the new alloys. This means that the heat stress to components, even in Wave Soldering, has increased considerably due to higher pre-heat and wave temperatures.

The Polypropylene Capacitors are especially sensitive to heat (melting point of Polypropylene is 160 – 170 °C). The Wave Soldering can be destructive especially for mechanically small Polypropylene Capacitors (Lead spacings 5-10 mm), and great care has to be taken when soldering them. The recommended solder profiles from Evox Rifa should be used. In case of doubt, Evox Rifa should be consulted. In general the Wave Soldering curve from IEC Publ. 61760-1 edition 2 gives a good guideline for successful soldering. See Figure 1.

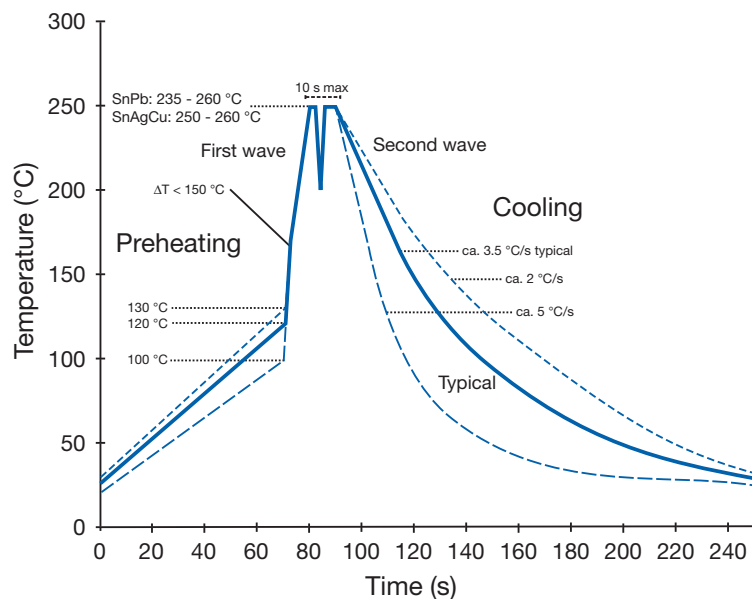

Figure 1

KEMET QUALITY

The quality of Evox Rifa's products and services is based on a continuous strive towards excellency throughout the whole organization. Skilled and motivated personnel, technical know-how and modern equipment combined with extensive quality assurance make Evox Rifa the supplier of components of the highest quality.

The up-to date quality tools like Statistical Process Control (SPC) in various forms, Failure Mode and Effect Analysis (FMEA), Accelerated Reliability Testing and Zero Defect Acceptance concept in final testing are the corner stones of the every day quality work. Cross-functional teams are routinely used in Problem Solving (8D method) with effective Failure Analysis support.

As a visible evidence of our quality, all the manufacturing units world wide are certified according to ISO 9001. In addition to that, the relevant factories have the automotive industry's ISO TS 16949 certifications. The

Finnish factory has also IECQ approval. Our well known EMI suppression capacitors carry the important safety marks for world wide applications.

Evox Rifa companies have the following certificates:

ISO 14001

P.T. Evox Rifa, Batam, Indonesia

ISO 9001

BHC Components

Evox Rifa AB, Gränna, Sweden

Evox Rifa Oy, Suomussalmi, Finland

Nantong Evox Rifa Electrolytics, P.R. China

P.T. Evox Rifa, Batam, Indonesia

ISO TS 16949

Evox Rifa AB, Gränna, Sweden

Evox Rifa Oy, Suomussalmi, Finland

Nantong Evox Rifa Electrolytics, P.R. China

P.T. Evox Rifa, Batam, Indonesia

IECQ

Evox Rifa Oy, Suomussalmi Finland

Customer in Focus

The only real measure of our total quality performance is the acceptance of our customers.

Evox Rifa's quality work has always been focused on the customer. We have actively made quality agreements with ambitious goal settings with World-Class Companies – small and large.

This active quality cooperation has been most fruitful to Evox Rifa by bringing in most modern quality tools, but especially by providing us with reliable feedback on the performance quality of our products and services.

The cooperation has not only lead to continuous improvement of the quality of our products, but sometimes also helped our customers to spot some weaknesses in their designs. A visible sign of these close links between Evox Rifa and various customers is the numerous prestigious customer approvals and the performance awards addressed to Evox Rifa and BHC Components.

IN-HOUSE RESEARCH AND DEVELOPMENT FOR TOMORROW'S NEEDS

Evox Rifa has over sixty years accumulated experience in developing a wide range of world-class capacitor products. Our leading position in the market with a wide product range is based on our deep knowledge of the materials and ways in which they can be used in capacitor designs to provide the best possible solutions.

Evox Rifa invests substantial human and

financial resources in finding new highly reliable and cost effective solutions for today's and tomorrow's needs. Our R&D department can simulate most operational conditions and apply our products to the envisaged working environment, giving to the customer optimized capacitors for a particular specification.

The simulation capabilities substantially shorten the design cycle of capacitors.

To assist in shortening the design cycle of our customers, we have brought our R&D department to our customers by providing them with a CAD software, which allows them to select the most suitable capacitors for their application (Fig. 1). For easy calculation of signal stresses, there is also a fast Fourier transform software available. In this software complicated signal forms can easily be simulated and analysed (Fig. 2 and 3).

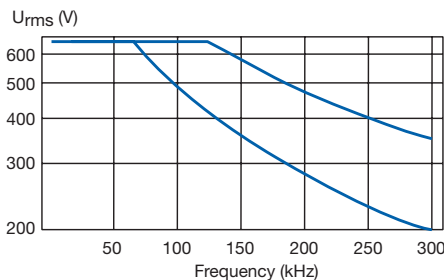

Fig. 1. From CAD software, showing max U_{rms} vs. frequency for two different capacitors

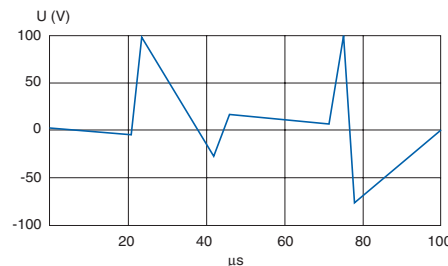

Fig. 2. Signal $s(t)$

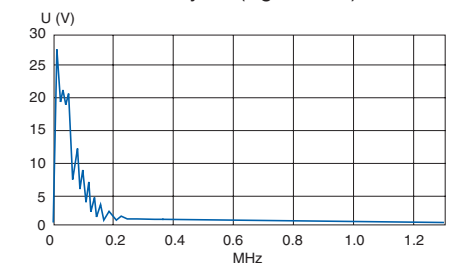

Fig. 3. Frequency spectrum

PRODUCT SPECIFICATION

All descriptions, drawings and other particulars (including dimensions, materials and performance data) given by Evox Rifa are as accurate as possible but, being given for general information, are not binding on Evox Rifa unless specifically agreed in writing. All dimensions and materials are, unless otherwise stated, subject to reasonable variations resulting from the raw material available or arising in the ordinary course of manufacture. Any performance data are based upon Evox Rifa's experience and are such as Evox Rifa normally expects to achieve.

WARRANTY, PRODUCT LIABILITY

Evox Rifa warrants that the goods manufactured by Evox Rifa are free from defects in design, material and workmanship.

Evox Rifa's liability under this warranty shall be limited to replacement or repair free of charge, at one of Evox Rifa's factories selected by Evox Rifa, provided that notification of such failure or defect is given to Evox Rifa immediately upon the same becoming apparent and that on Evox Rifa's request and instruction the goods are promptly returned to Evox Rifa carriage paid by buyer.

In case the goods thus returned as defective, prove to be without fault or defect, Evox Rifa is entitled to charge buyer 100% of the value of the returned goods.

If the goods supplied or part thereof are not manufactured by or branded Evox Rifa, Evox Rifa will only extend to the buyer the benefit of the warranty granted by the manufacturer of the goods.

Evox Rifa's liability is further limited to a period of 12 months from the date of shipment

to buyer.

Evox Rifa shall not be liable for any defect which is due to accident, fair wear and tear, negligent use, tampering, improper handling, improper use, improper operation or improper storage or any other default on the part of any person other than Evox Rifa.

Evox Rifa shall have no other liabilities in case of defective goods than those stated above and shall under no circumstances be liable for any consequential loss or damage arising from the use of goods sold by Evox Rifa. Liability under paragraph 823 BGB is expressly excluded.

The above limitations of Evox Rifa's liability for defective goods shall apply also with regard to product liability, and Evox Rifa shall have no responsibility for injury to persons or for damage to goods or property of any kind.

In case of product liability claims from third parties against Evox Rifa, not falling within Evox Rifa's liability in accordance with the above, buyer shall hold Evox Rifa harmless.