

Replacing MnO₂ with Conductive Polymer in Tantalum Capacitors

John D. Prymak
KEMET Electronics Corp.
Greenville, SC 29606 USA
Telephone: 864-963-6573
FAX: 864-967-6876

ABSTRACT

In the intensive efforts to reduce the effective series resistance (ESR) in tantalum capacitors, the main impediment is the semiconductor nature of the manganese dioxide (MnO₂) material. This material is the basis for the cathode plate as it exists in the tantalum capacitor and has a significant material resistivity that accounts for most of the ESR. Replacing this material with a more conductive material is restricted in that this material also forms the basis for the “self-healing” phenomenon within the solid tantalum capacitor. Conductive polymers not only respond to these challenges, but they bring one very important change – no ignitions.

Anode and Dielectric

The basis for the tantalum capacitor is the anode plate structure. This starts out as a pressed pellet that is then sintered to create an extremely porous block of continuously connected tantalum. A wire is inserted in the pellet during the die press or welded to the pellet structure after pressing and a preliminary sintering process. The sintering process is completed at temperatures approaching 2000°C, and in a vacuum.

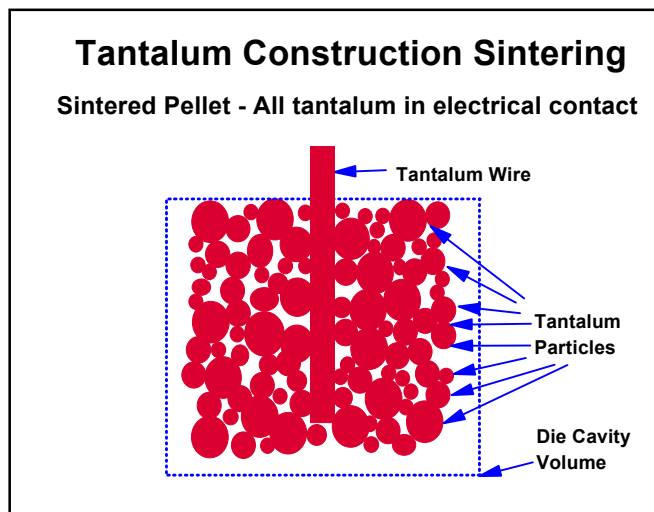

This pellet structure at this point contains all tantalum particles, and each of them is in contact with other tantalum particles. This contact is both physical and electrical. Again, this is the basis of the anode plate structure within this capacitor. The continuously contacting tantalum particles still allow an enormous amount of porosity to exist, and this porosity creates a tremendous amount of surface area of tantalum. It is this very large surface area within this structure where the tantalum capacitor achieves some of its volumetric advantage over all other commercial capacitor types.

This porous metal pellet is then dipped into an electrolyte solution, and current is created with the tantalum pellet positively biased. The electrolyte solution is chosen such that it readily gives up oxygen to the tantalum metal in contact with the electrolyte under these biased conditions. The oxygen is absorbed by the tantalum and a coating of tantalum-pentoxide (Ta₂O₅) is created on all exposed surfaces of the tantalum. The thickness of the Ta₂O₅ coating is determined by the bias voltage applied during this process.

The Ta₂O₅ is the dielectric in this capacitor. The material is amorphous in structure (glass-like) and retains certain optical qualities. The thickness can be determined after this process step as the coloration of the pellet is associated with a specific thickness. This coloration is also used in failure analysis to verify that the device was formed to the proper thickness for the intended voltage rating of the part. The formation thickness is in the range of ~20 angstroms per volt – a very efficient utilization of thickness.

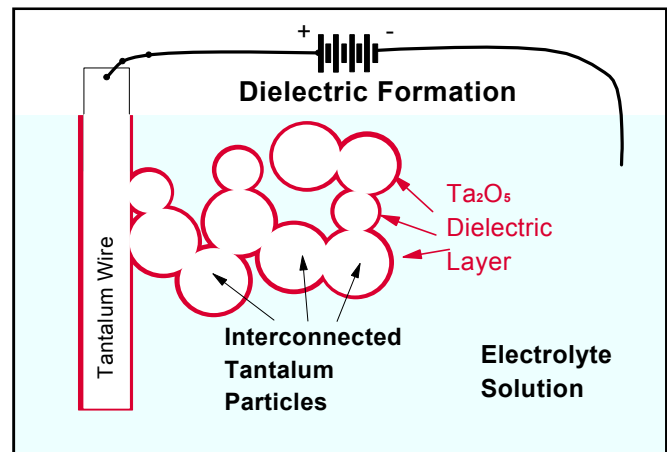

Because this dielectric is created in an electrolytic process of anodization, it can be reversed. By applying a bias such that the tantalum plate structure is negatively biased, the oxygen can be drawn out of the Ta₂O₅ dielectric region, diminishing the insulative properties of this dielectric. For this reason, the tantalum (as all electrolytics) is a polar type capacitor.

The anode plate structure and the dielectric structure for the capacitor now exists after the electrolytic formation. The next step is the creation of the secondary electrode plate for the capacitor structure. Since this electrode plate will always be biased negatively, it may be referred to as the cathode plate.

The extremely porous nature of the pellet structure requires that the cathode plate be applied with some type of liquid or vapor process. These processes will allow penetration into the depths of the structure to facilitate the deposition of material

through the pore structure, and covering the entire surface area of the newly created Ta_2O_5 . The “wet” tantalum capacitors use a liquid electrolyte solution as the contacting medium for all the exposed surfaces of Ta_2O_5 , but the wet electrolyte presents problems of containment, out-gassing, and temperature restrictions. Surface mount capability requires that the cathode structure be solid in nature.

Cathode – MnO_2 by Impregnation

Choosing any conductive material that could be deposited within the pellet would open the door to many possibilities of materials. The MnO_2 material for this application was discovered in the Bell Laboratories at the same time the transistor was discovered.

Dipping the pellet structure in manganese nitrate solution, and then drying it, creates the deposition of MnO_2 within the pellet. This dip and dry process step is repeated over a number of cycles, with the manganese nitrate solution starting out as thin and getting thicker with successive steps.

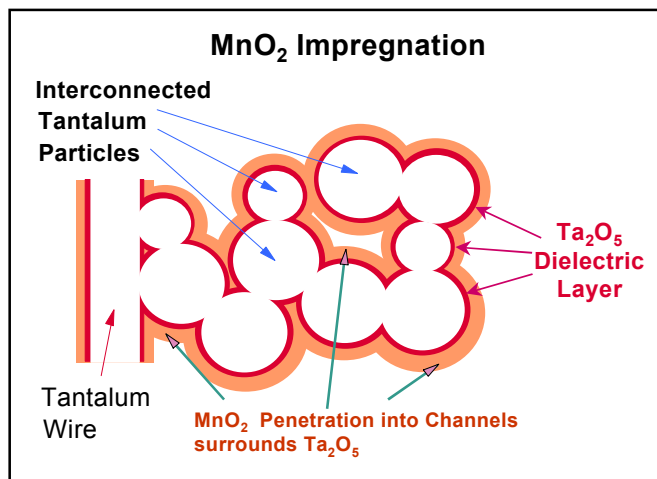

The MnO_2 is driven out of the solution during the drying process and forms a solid coating over the surface of the dielectric. Once this deposition is complete, the tantalum capacitor exists as a formed capacitor with two conductive plates separated by the dielectric. Packaging of this capacitor for circuit application requires that conductive silver coating be applied to the outer shell of the pellet, in direct contact with the MnO_2 coverage that extends to, and includes, the outside surface of the pellet.

Direct application of the silver to the MnO_2 creates a high interfacial resistance. This is overcome by applying a thin graphite or carbon coating to the outer surface of the pellet, prior to the silver.

The silver is then connected to a leadframe plate with a conductive epoxy. The tantalum wire rising out of the pellet (the anode contact) is then welded to another leadframe plate. The structure is molded in an epoxy, with the leadframes bent beneath the structure to create a surface mountable capacitor.

The tantalum capacitor now exists with a good, conductive, anode plate material (tantalum resistivity $\sim 13\mu\Omega\text{-cm}$), an extremely efficient thickness ($\sim 20 \text{ \AA/volt}$) of dielectric ($k \sim 27$),

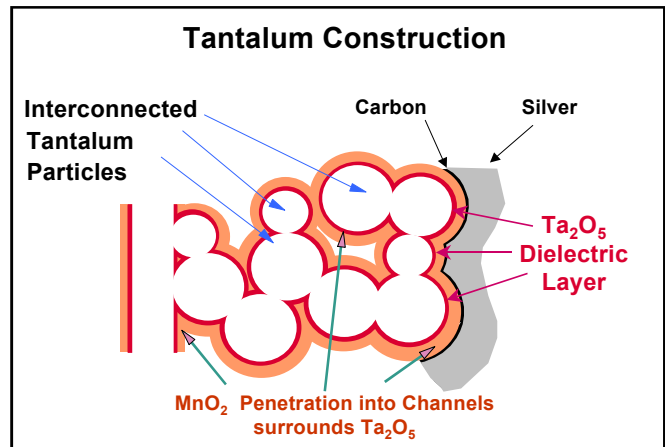

but a semiconductor material as the cathode plate (MnO_2 resistivity $\sim 2\Omega\text{-cm}$).

RC-Ladder Performance

Because of the high resistivity of the MnO_2 cathode structure, the performance of the tantalum capacitor is very much like that of a RC-Ladder circuit.

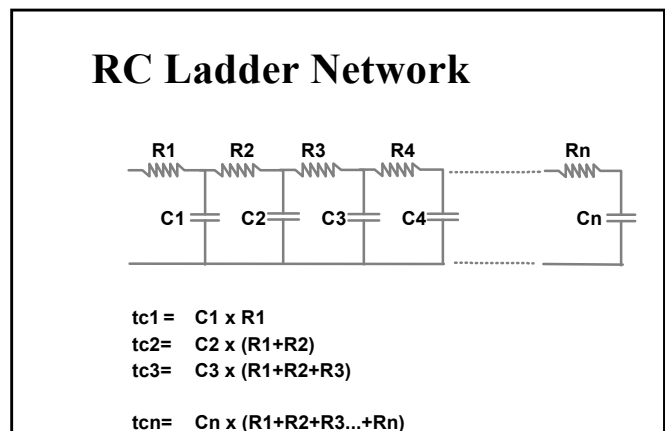

The RC time constants for the capacitive elements increase as progressing to the right (towards C_n). There is additional resistance added to the capacitor element from its location to the termination points of the capacitor. This shows up as decaying capacitance with increasing frequency. Shown below is the capacitance “roll-off” measured for a commercial tantalum ca-

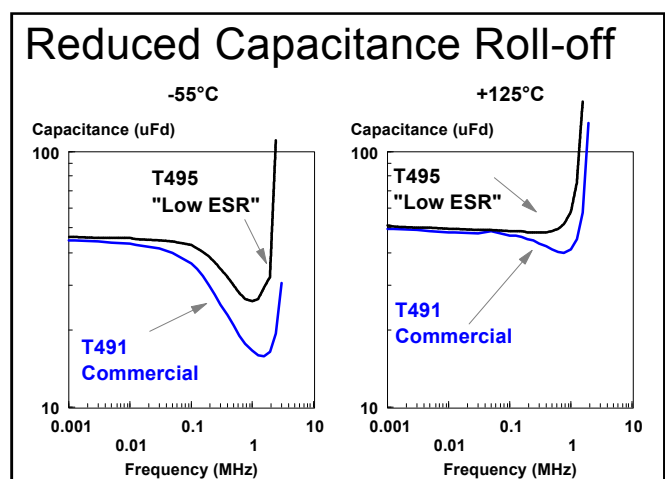

capacitor versus a “special, low ESR” design capacitor (T495). They both utilize MnO₂ in their structures, with the T495 designed to optimize geometries of design and materials to enhance its performance.

In a time domain representation, this can also show up as lower apparent capacitance with shorter time-periods. The following display depicts measured capacitance versus time taken as an interpretation of the dv/dt pulse when subjecting the capacitors to a constant current pulse. The ceramic capacitors have no inherent RC-Ladder effect, whereas the electrolytics do.

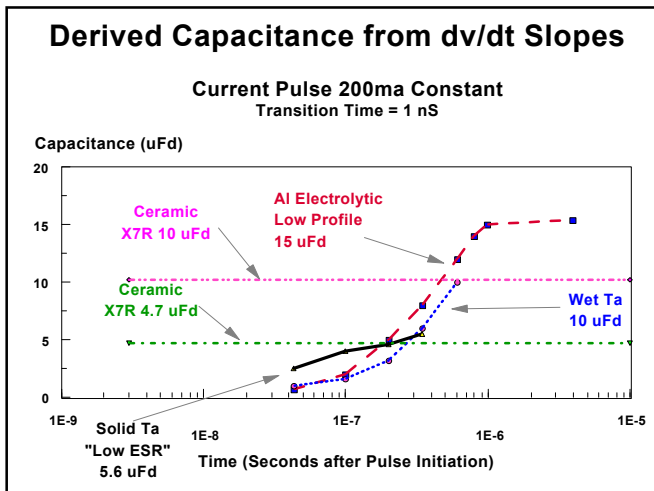

The physical presentation of the RC-Ladder structure in the tantalum capacitor can readily be seen in the following diagram. As the MnO₂ meanders in the channel adjacent to the tantalum string, it offers increasing resistivity to the deeper capacitive elements in the pellet. As frequency increases, the deeper capacitive elements are effectively isolated from the external circuit. As frequency increases further still, more and more capacitive elements are eliminated from responding. Eventually, only those capacitive elements immediately adjacent to the silver coating can respond.

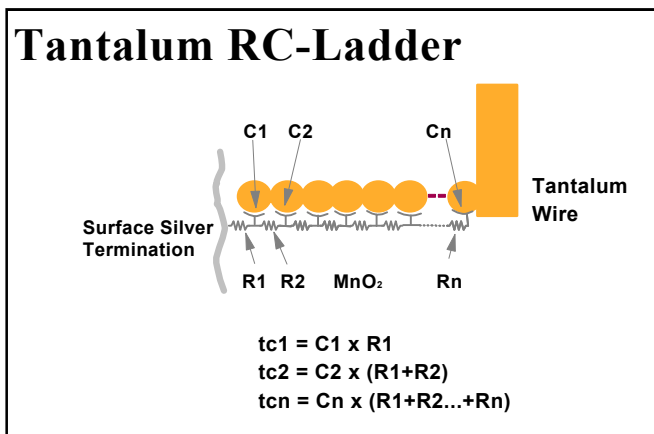

The MnO₂ cathode plate material is the dominant contributor to the ESR composition within the tantalum capacitor. Why stay with the MnO₂ instead of a more conductive material? The answer is the self-healing capability with the MnO₂ structure.

MnO₂ Self-Healing in Tantalum Capacitors

The structure of the tantalum capacitor utilizes an extremely thin, glass-like material for its dielectric. Throughout the process, there are possibilities of introducing foreign materials into the structure. There are extremely low levels of contaminants within the processed tantalum powder, but they are there nevertheless. The dip and dry process introduces multiple thermal cycle exposures (+23°C to +270°C) to the combination of tantalum, Ta₂O₅ dielectric, and the MnO₂ structure. All of these combined with the enormous surface area in the tantalum capacitor leads to defect sites within the capacitor structure.

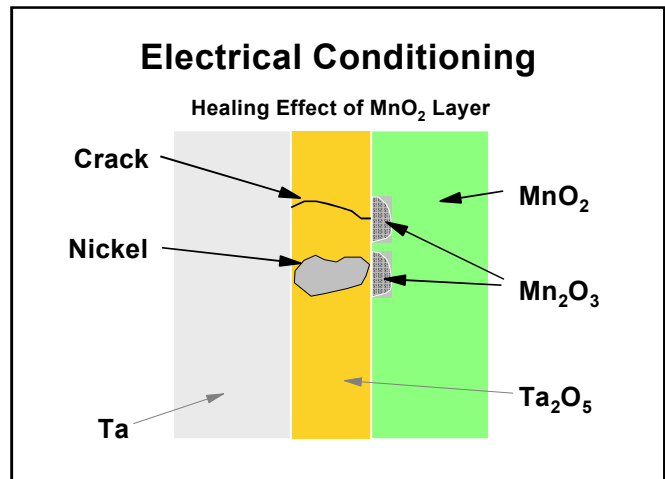

The very first step after the capacitor can be electrified is not capacitance, but aging. Aging is a process that activates the self-healing mechanism of the MnO₂ to clear the defect sites from the capacitor structure. This electrification is an application of an increasing bias through high resistance to limit the current. A fault site is created or uncovered when the voltage stress causes a breakdown of the dielectric and higher currents rush through this site. At the fault site there is a concentration of current in the MnO₂ adjacent to the fault. This current causes the MnO₂ to heat up locally at the point of fault current entry. When the MnO₂ heats up to ~450°C, the MnO₂ gives off oxygen, converting to a lower oxygen state such as Mn₂O₃ at that fault site. The most conductive of the manganese oxide combinations is MnO₂ and reducing the oxygen content causes the resistivity to increase dramatically.

This conversion, in effect creates a cap over the fault site, thereby restricting the current flow into the fault site. These conversions are permanent, sealing these faulty sites for the life of the capacitor.

Without this self-healing capability, the capacitor yield would be minimal. There would be no tantalum capacitors for commercial applications. The exclusivity of the MnO₂ to possess this capability has led a long and determined search for a replacement.

Ignition Failures

The self-healing is limited to circuits where there is some resistivity associated with the source voltage. This resistivity reduces the current to lower levels, allowing a time factor for

the conversion of the MnO_2 to lower oxide states, to take place. If the current is unlimited, the self-healing process cannot convert the MnO_2 fast enough to eliminate the defect site.

The MnO_2 converts when it reaches a temperature of $\sim 450^\circ C$, but there is a time factor in the thermal rise. Unlimited current causes the initiation of the conversion, but also allows a degradation of the Ta_2O_5 to take place. At $\sim 500^\circ C$, the Ta_2O_5 changes from an amorphous state to a crystalline state. Crystalline Ta_2O_5 is conductive. When this conversion starts, it progresses radially outward from the fault site, diminishing the current concentration in the MnO_2 , and enlarging the contact area with MnO_2 . Now the tantalum starts to oxidize and feeds on the oxygen in the MnO_2 . The tantalum oxidation then continues as an exothermic reaction to consumption.

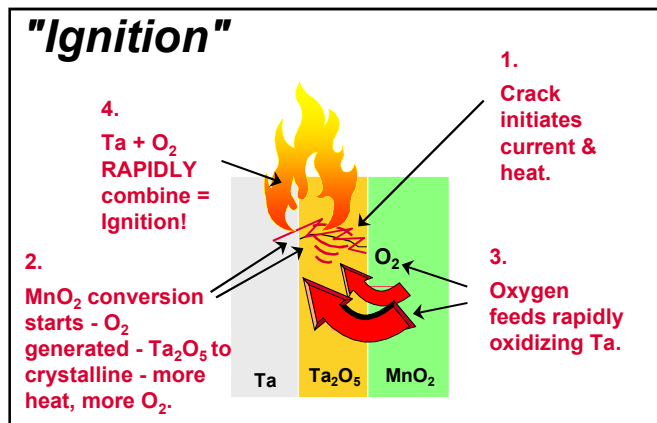

The same material that allows for the self-healing can become an oxidizing agent in an ignition failure.

Conductive Polymer Self-Healing

The self-healing criteria for the cathode plate structure could not be dismissed. Experimentation with various conductive polymers established a compatible material with capability for this feature.

There are two arguments as to why the self-healing mechanism works with the polymers. The first deals with the fairly low vaporization temperatures of these polymers. It is speculated that current entering a fault site adjacent to the polymer causes it to heat up, localized to that point. This heat results in a vaporization of the polymer, clearing the contact to the fault

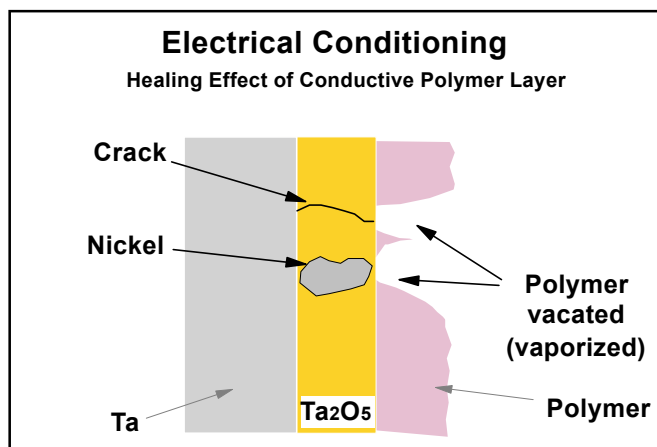

site, thereby eliminating it.

The second theory speculates that as the fault draws current, the polymer heats up. The heated polymer will readily oxidize, and any available oxygen is absorbed, thereby increasing its resistance. This theory speculates a "capping effect" in the same manner as the MnO_2 caps a fault site.

Regardless of which theory is correct, or even if a combination of both exists, tantalum capacitors can be built with con-

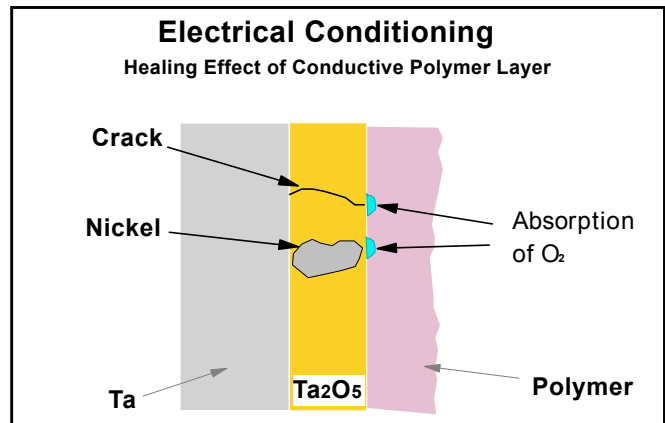

ductive polymers replacing the MnO_2 as the cathode plate material, and with yields equal to the latter.

The application of the polymer to the anode actually involves polymerization within the anode structure. The pellet is dipped in a monomer solution, and polymerization takes place with the pellet structure. This cathode application also involves multiple cycles, but the drying process is at or very near room temperature (eliminates multiple thermal cycles).

Higher Conductivity – Lower ESR

The polymer material in itself has lower resistivity or higher conductivity than the MnO_2 material. The pellet structure is exactly the same as before, as is the dielectric. The MnO_2 is replaced with the conductive polymer, effectively reducing the resistance of each of the steps in the RC-Ladder. The structure remains the same, but by reducing the resistive steps in the ladder, the effects are diminished.

Shown in the following diagram is the capacitance versus frequency response of similar anodes that were processed with

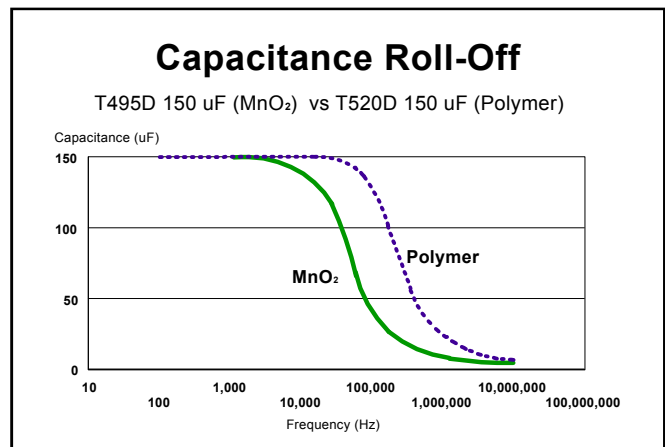

the polymer, versus the old MnO₂ process. The capacitance will still show a roll-off (after all the structure is exactly the same), but the roll-off occurs at a much higher frequency. In this example, at 100 kHz, the MnO₂ part has lost ~33% of its original capacitance, whereas the polymer has almost all of its original capacitance responding to the circuit.

This impacts the impedance and ESR versus frequency re-

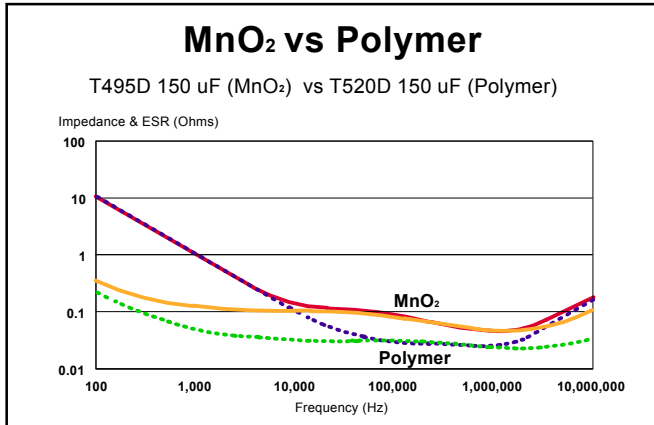

sponses as shown below. Again, these anode pellets are identical, and it is only the cathode process and materials that differ.

Mechanically Gentler

Looking at the composite structure of the tantalum pellet, the dielectric and the cathode, we see three materials with individual coefficients of thermal expansion (CTE). The tantalum and Ta₂O₅ materials should be fairly close to each other but the MnO₂ is quite different. Looking at a “neck-down” structure of one of the channels in the pellet, the MnO₂ is filling the neck with a hard, crystalline material.

Induced Process Stress - MnO₂

In the tantalum anode pellet, areas of constriction exist where tantalum particles form closed loop around an open channel.

The MnO₂ filling this enclosure is a **hard, crystalline** material.

Impregnation process involves dip at +25°C and conversion at +270°C. Stresses might be root of cracks in dielectric.

Mismatches in CTEs can lead to the creation of cracks in the dielectric, especially where the tantalum particles join each other.

Here the MnO₂ creates a wedge between the particles and their anodized coatings. These mismatches generate forces proportional to the degree of mismatch and the temperature excursion the device is exposed to. It is possible that the process of putting the MnO₂ within this structure can actually create faults sites because of this mismatch.

Reduced Process Stress - Polymer

The polymer material is **soft** and **elastic**. The forces generated because of mismatches in CTEs are insignificant when compared to MnO₂. The process involves conversion at room temperature after each dip cycle -- not at any elevated temperatures.

Replacing this cathode material with the polymer, results in the deposition of a soft, elastic type material. Forces generated by mismatches in CTEs are almost entirely self-absorbed within the material itself.

No Ignitions!

Eliminating the MnO₂ also eliminates the source of oxygen from impacting the breakdown of this capacitor in a high current application. The polymer has almost no oxygen, and any created causes its resistivity to increase dramatically. The polymer eliminates the abundant oxygen source. At the bottom of this page is a scanned image of parts that were subjected to over-voltage until breakdown. The even units are the polymer devices, while the odd units are the MnO₂ devices. There are no ignitions with the polymer.

Bibliography

- Jordan, Edward C.; Reference Data for Engineers: Radio, Electronics, Computer, and Communications; Howard W. Sams & Co., Inc.; 1985
- Nakata, Takehiko and K. Morimoto, Y. Saiki, T. Nishiyama; “History of the Development of Tantalum Capacitor and Future Trend”; International Symposium on Tantalum and Niobium; Goslar, Germany; September, 1995
- Prymak, John; “New Tantalum Capacitors in Power Supply Applications”; 1998 IEEE Industry Applications Society Annual Meeting; October 1998; St. Louis, Mo.
- Prymak, John; “Low ESR Tantalum Developments for SMPS Applications”; PCIM Inter '98 Japan Conference; April 1998, Japan

