

Construction

Multilayer metallized paper encapsulated and impregnated in self-extinguishing material meeting the requirements of UL 94V-0.

Benefits

- Approvals: ENEC, UL
- Rated voltage: 1000VDC, 250VAC 50/60Hz
- Capacitance range: 0.022 μ F–0.1 μ F
- Capacitance tolerance: \pm 20%
- Resistance range: 100 Ω
- Resistance tolerance: \pm 30%
- Pitch: 15.2mm–25.4mm
- Climatic category: 40/085/56/B, IEC 60068-1
- Tape and reel packaging in accordance with IEC 60286-2
- RoHS compliance and lead-free terminations
- Operating temperature range of -40°C to +85°C
- Excellent self-healing properties which ensure long life even when subjected to frequent over-voltages
- Good resistance to ionization due to impregnated paper dielectric
- High dU/dt capability
- Impregnated paper ensures excellent stability and reliability properties, particularly in applications with continuous operation

Applications

For worldwide use in contact protection, contact interference suppression and transient suppression.

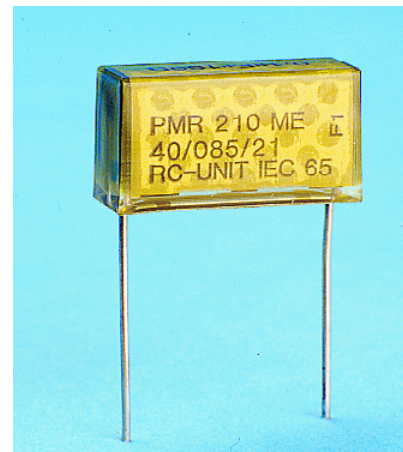

Ordering Information

PMR210	M	B	5220	M	100	R30
Series	Rated Voltage	Pitch	Capacitance Code (pF)	Capacitance Tolerance	Resistance (Ω)	Packing Option and Leadform
RC Snubber, Metallized Paper	M = 250VAC	B = 15.2 C = 20.3 E = 25.4	Digits 2-4 indicates the first three digits of the capacitance value. First digit indicates the total number of digits in the capacitance value.	M = \pm 20%	Resistance Value in Ω	see Table 1

Ordering Options Table

Standard Packaging Style	Lead Length	Ordering Code
	(mm)	
Ammo Pack		R19TA
Tape & Reel 360 mm		R19T0
Tape & Reel 500 mm		R19T1
Loose, Short Leads	4 ^{+0/-1}	R04
Loose, Long Leads	17 ^{+0/-1}	R17
Loose, Long Leads	30 ⁺⁵	R30
Other options available on request		

Dimension Table

Pitch	Outer Dimension		
	B	H	L
15.2	7.3	13	18.5
15.2	8.5	14.3	18.5
20.3	9	15	24
20.3	11.3	16.5	24
25.4	10.6	16.1	30.5

Leadspacing Table

p	d	std l	min l	b
15.2 ± 0.4	0.8	30	6	± 0.4
20.3 ± 0.4	0.8	30	6	± 0.4
25.4 ± 0.4	1.0	30	6	± 0.7
Tolerance in Lead Length		< 30mm +2 / -0		
		30mm +5 / -0		

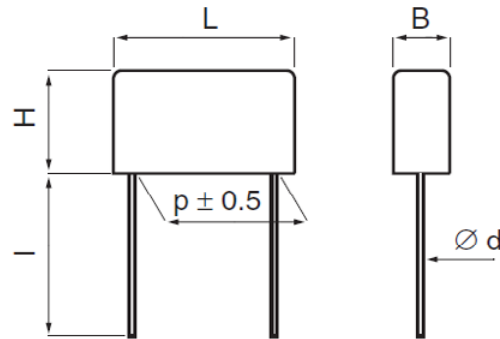

Technical Data

Rated Voltage	250VAC 50/60Hz	
Capacitance Range	0.022 μ F–0.1 μ F	
Capacitance Tolerance	\pm 20%	
Resistance Range	100 Ω	
Resistance Tolerance	\pm 30%	
Temperature Range	-40°C to +85°C	
Climatic Category	40/085/56/B	
Approvals	ENEC, UL	
Peak Pulse Voltage	1000V	
Series Resistance	The series resistance is defined at 1kHz for RC \geq 50 μ s and at 100kHz for RC < 50 μ s	
Insulation Resistance	\geq 1,000M Ω	
Pulse Current	Max 12A repetitive. Max 20A peak for occasional transients.	
Test Voltage between Terminals	The 100% screening factory test is carried out at 3000VDC. The voltage level is selected to meet the requirements in applicable equipment standards. All electrical characteristics are checked after the test.	
In DC Applications	Recommended voltage \leq 1000VDC	
Power Ratings	The average losses may reach 0.5W provided the surface temperature does not exceed + 85°C. For maximum permitted power dissipation vs. temperature, see Derating Curves.	
Derating Curves	<p>Maximum allowable power dissipation vs ambient temperature and case sizes.</p>	
	Curve	Dimension B
	1	7.3
	1	8.5
	2	9
	3	11.3
	4	10.6

Environmental Test Data

Test	IEC Publication	Procedure
Vibration	IEC 60068-2-6 Test Fc	3 directions at 2 hours each 10-500Hz at 0.75mm or 98m/s ²
Bump	IEC 60068-2-29 Test Eb	4000 bumps at 390m/s ²
Solderability	IEC 60068-2-20 Test Ta	Wetting time dor d > 0.8 < 1.5s
Damp Heat Steady State	IEC 60068-2-78 Test Cab	+40°C and 93% R.H., 56 days
Active Flammability	IEC 60384-14	UR + 20 surge pulses at 2.5 kV (pulse every 5 s)
Passive Flammability	IEC 60384-14	IEC 60384-1, IEC 60695-11-5 Needle Flame Test
Damp Heat Steady State	IEC 60068-2-78 Test Cab	+40°C and 90 - 95% R.H., 56 days

Environmental Compliance

All KEMET EMI capacitors are RoHS compliant.



RoHS Compliant

Approvals



Certification Body	Specification	File Number
	EN/IEC 60384-14	SE/0140-21A
	UL 1414 (250VAC)	E73869

Table 1 – Ratings & Part Number Reference

Lead Space	Cap Value (μF)	Resistance Ω	Max dimensions in mm			Quantity per package			Weight Grams	F Article Code	Part Number
			B	H	L	R06	R30	Reel			
15.2	0.022	100	7.3	13	18.5	400	800	400	3	P410QM223M250AH101	PMR210MB5220M100R30
15.2	0.033	100	8.5	14.3	18.5	300	500	350	3.8	P410QS333M250AH101	PMR210MB5330M100R30
20.3	0.047	100	9	15	24	200	1200	250	5	P410CJ473M250AH101	PMR210MC5470M100R30
20.3	0.068	100	11.3	16.5	24	150	1000	180	7	P410CP683M250AH101	PMR210MC5680M100R30
25.4	0.1	100	10.6	16.1	30.5	150	1000		8	P410EE104M250AH101	PMR210ME6100M100R30
Lead Space	Cap Value (μF)	Resistance Ω	B (mm)	H (mm)	L (mm)	R06	R30	Reel	Weight Grams	F Article Code	Part Number

Soldering Process

The implementation of RoHS Directive has forced to select SnAuCu (SAC) alloys or SnCu alloys as primary solder. This has increased the liquidus temperature from that of 183°C for SnPb eutectic alloy to 217–221°C for the new alloys. This means that the heat stress to components, even in wave soldering, has increased considerably due to higher pre-heat and wave temperatures. The Polypropylene Capacitors are especially sensitive to heat (melting point of Polypropylene is 160–170°C). The wave soldering can be destructive especially for mechanically small Polypropylene Capacitors (lead spacings 5-10 mm), and great care has to be taken when soldering them. The recommended solder profiles from KEMET should be used. In case of doubt, KEMET should be consulted. In general the wave soldering curve from IEC Publication 61760-1 edition 2 gives a good guideline for successful soldering.

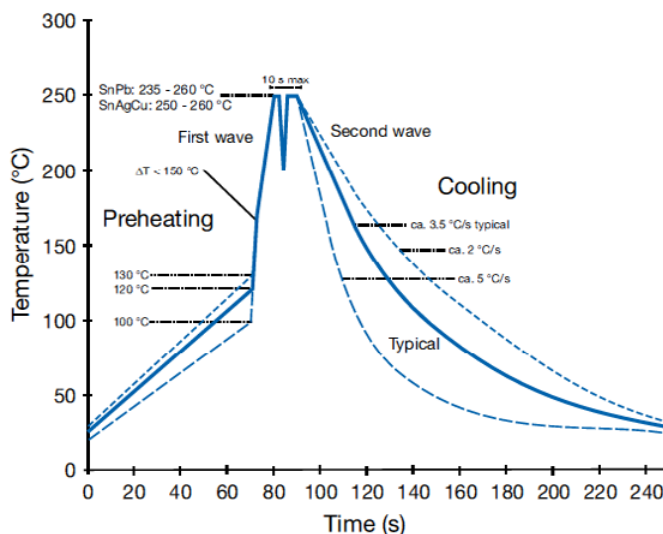

Marking

- Manufacturer's logo
- Article series
- RC unit
- Rated capacitance
- Rated resistance
- Rated voltage
- Manufacturing date code
- IEC climatic category
- Circuit diagram
- Passive flammability class
- Manufacturing date code

Packaging

The taping is carried out in accordance with IEC 60286-2.

Lead spacing 5 mm

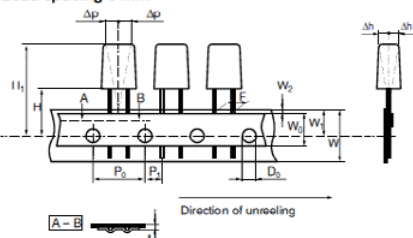

Lead spacing 7.5 mm

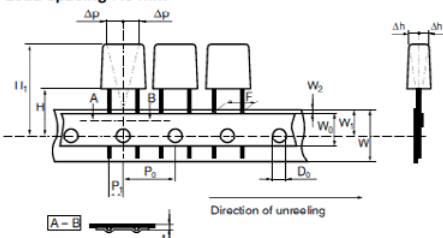

Lead spacing 10 and 15 mm

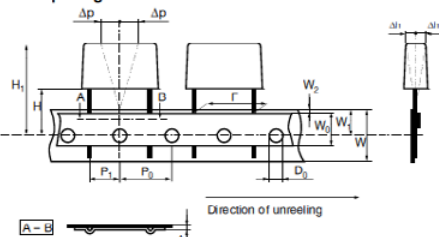

Lead spacing 22.5 and 27.5 mm

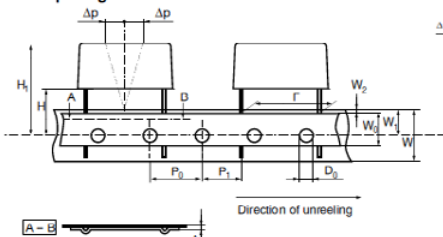

Crimped leads

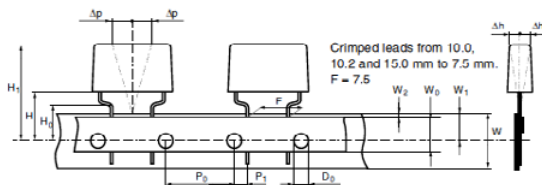

Taping Specification

	Dimensions in mm					Standard IEC 60286-2
Lead spacing, (Tol. +0.6/-0.1)	F	5.0/7.5	7.5 Crimped Leads	10.0/15.0	22.5/27.5	F
Carrier tape width, ±0.5	W	18	18	18	18	18 (+1.0/-0.5)
Hold-down tape width, ±0.3	W ₀	9	12	12	12	
Position of sprocket hole, ±0.5	W ₁	9	9	9	9	9 (+0.75/-0.5)
Distance between tapes, max.	W ₂	3	3	3	3	3
Sprocket hole diameter, ±0.2	D ₀	4	4	4	4	4
Feed hole pitch, ±0.3	P ₀ ¹⁾	12.7	15/12.7	12.7	12.7	12.7/15
Distance lead – feed hole, ±0.7	P ₁	3.85/3.75	3.75	7.7/5.2	5.3	P ₁
Max deviation tape – plane	Δp	1.3	1.3	1.3	1.3	1.3
Max lateral deviation	Δh	2	2	2	2	2
Total thickness, ±0.2	t	0.7	0.7	0.7	0.9 max	0.9 max
Sprocket hole/cap body	H ²⁾	18.5 ±0.5 16.5 ±0.5		18.5 ±0.5 16.5 ±0.5	18.5 ±0.5	18.0 (+2/-0)
Sprocket hole/crimped leads	H ₀ ²⁾		16 ±0.5 18 ±0.5			16 ±0.5
Sprocket hole/top of cap body, max	H ₁ ³⁾	32/31 max	40 max	43 max	58	58 max

¹⁾ Cumulative pitch error

²⁾ Alternatives for different insertion machines

³⁾ Depending on case size

Note: Crimped leads available on request

Reel Specification

Dimensions in mm			Tolerance
Reel diameter	A	360/500	max
Hub diameter	N	80	min
Arbor hole	C	30	±1
Total reel width measured at hub	W2	58	max

The standard packing for lead space ≤15 mm is 360 mm reel and for lead space >15 mm 500 mm reel.

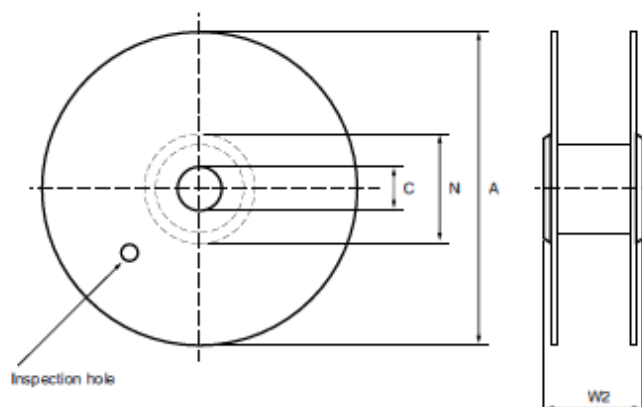

Ammo Pack Specification

Dimensions in mm		Lead spacing, mm	
		5, 7.5, 10	15, 22.5, 27.5, 37.5
Height	H	330	(135 or 200 for CQ depending on capacitance value)
Width	W	330	(335 for CQ)
Thickness	T	50	

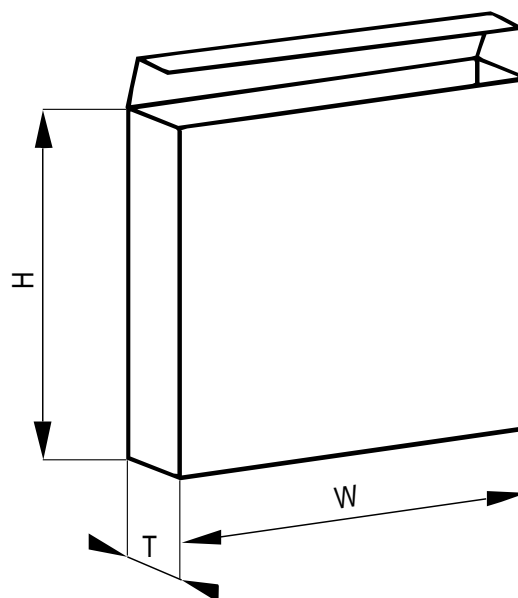

The Manufacturing Date Code Y Z, according to IEC 60062

where Y = year, Z = month									
Year	Code	Year	Code	Year	Code	Month	Code	Month	Code
1991	B	2001	N	2011	B	Jan	1	July	7
1992	C	2002	P	2012	C	Febr	2	Aug	8
1993	D	2003	R	2013	D	March	3	Sept	9
1994	E	2004	S	2014	E	April	4	Oct	O
1995	F	2005	T	2015	F	May	5	Nov	N
1996	H	2006	U	2016	H	June	6	Dec	D
1997	J	2007	V	2017	J				
1998	K	2008	W	2018	K				
1999	L	2009	X	2019	L				
2000	M	2010	A	2020	M				

KEMET Corporation World Headquarters

2835 KEMET Way
Simpsonville, SC 29681

Mailing Address:
P.O. Box 5928
Greenville, SC 29606

www.kemet.com
Tel: 864-963-6300
Fax: 864-963-6521

Corporate Offices

Fort Lauderdale, FL
Tel: 954-766-2800

North America

Southeast

Lake Mary, FL
Tel: 407-855-8886

Northeast

Wilmington, MA
Tel: 978-658-1663

West Chester, PA
Tel: 610-692-4642

Central

Schaumburg, IL
Tel: 847-882-3590

Carmel, IN
Tel: 317-706-6742

West

Milpitas, CA
Tel: 408-433-9950

Mexico

Zapopan, Jalisco
Tel: 52-33-3123-2141

Europe

Southern Europe

Geneva, Switzerland
Tel: 41-22-715-0100

Paris, France
Tel: 33-1-4646-1009

Sasso Marconi, Italy
Tel: 39-051-939111

Milan, Italy
Tel: 39-02-57518176

Rome, Italy
Tel: 39-06-23231718

Madrid, Spain
Tel: 34-91-804-4303

Central Europe

Landsberg, Germany
Tel: 49-8191-3350800

Dortmund, Germany
Tel: 49-2307-3619672

Kwidzyn, Poland
Tel: 48-55-279-7025

Northern Europe

Bishop's Stortford, United Kingdom
Tel: 44-1279-757201

Weymouth, United Kingdom
Tel: 44-1305-830747

Coatbridge, Scotland
Tel: 44-1236-434455

Färjestaden, Sweden
Tel: 46-485-563934

Espoo, Finland
Tel: 358-9-5406-5000

Asia

Northeast Asia

Hong Kong
Tel: 852-2305-1168

Shenzhen, China
Tel: 86-755-2518-1306

Beijing, China
Tel: 86-10-5829-1711

Shanghai, China
Tel: 86-21-6447-0707

Taipei, Taiwan
Tel: 886-2-27528585

Southeast Asia

Singapore
Tel: 65-6586-1900

Penang, Malaysia
Tel: 60-4-6430200

Bangalore, India
Tel: 91-806-53-76817

Note: KEMET reserves the right to modify minor details of internal and external construction at any time in the interest of product improvement. KEMET does not assume any responsibility for infringement that might result from the use of KEMET Capacitors in potential circuit designs. KEMET is a registered trademark of KEMET Electronics Corporation.

Other KEMET Resources

Tools	
Resource	Location
Configure A Part: CapEdge	http://capacitoredge.kemet.com
SPICE & FIT Software	http://www.kemet.com/spice
Search Our FAQs: KnowledgeEdge	http://www.kemet.com/keask

Product Information	
Resource	Location
Products	http://www.kemet.com/products
Technical Resources (Including Soldering Techniques)	http://www.kemet.com/technicalpapers
RoHS Statement	http://www.kemet.com/rohs
Quality Documents	http://www.kemet.com/qualitydocuments

Product Request	
Resource	Location
Sample Request	http://www.kemet.com/sample
Engineering Kit Request	http://www.kemet.com/kits

Contact	
Resource	Location
Website	www.kemet.com
Contact Us	http://www.kemet.com/contact
Investor Relations	http://www.kemet.com/ir
Call Us	1-877-MyKEMET
Twitter	http://twitter.com/kemetcapacitors

Disclaimer

All product specifications, statements, information and data (collectively, the "Information") are subject to change without notice.

All Information given herein is believed to be accurate and reliable, but is presented without guarantee, warranty, or responsibility of any kind, expressed or implied.

Statements of suitability for certain applications are based on our knowledge of typical operating conditions for such applications, but are not intended to constitute – and we specifically disclaim – any warranty concerning suitability for a specific customer application or use. This Information is intended for use only by customers who have the requisite experience and capability to determine the correct products for their application. Any technical advice inferred from this Information or otherwise provided by us with reference to the use of our products is given gratis, and we assume no obligation or liability for the advice given or results obtained.

Although we design and manufacture our products to the most stringent quality and safety standards, given the current state of the art, isolated component failures may still occur. Accordingly, customer applications which require a high degree of reliability or safety should employ suitable designs or other safeguards (such as installation of protective circuitry or redundancies) in order to ensure that the failure of an electrical component does not result in a risk of personal injury or property damage.

Although all product-related warnings, cautions and notes must be observed, the customer should not assume that all safety measures are indicated or that other measures may not be required.

