

Ød ±0.05	p = 5mm	p = 10mm
	0.6	0.7

### METALLIZED POLYESTER FILM CAPACITOR WITH INTEGRATED BIDIRECTIONAL SUPPRESSOR DIODE HIGH PERFORMANCE PEAK REDUCTION

**Typical applications:** these component units are used to strongly reduce transient phenomena and act as EMI-RFI suppressors for automotive motors and other suppression applications of very high performance.

- Engine blower fans
- Heating/air-conditioning blowers
- Electric window regulators
- Electric windshield wipers
- Central locking systems
- Electric sun roofs
- Fuel/oil pumps
- Electrically operated seats

PRODUCT CODE: **F5B**

Pitch (mm)	Maximum dimensions (mm)		
	B max	H max	L max
5.0	B +0.1	H +0.1	L +0.3
10.0	B +0.1	H +0.1	L +0.35

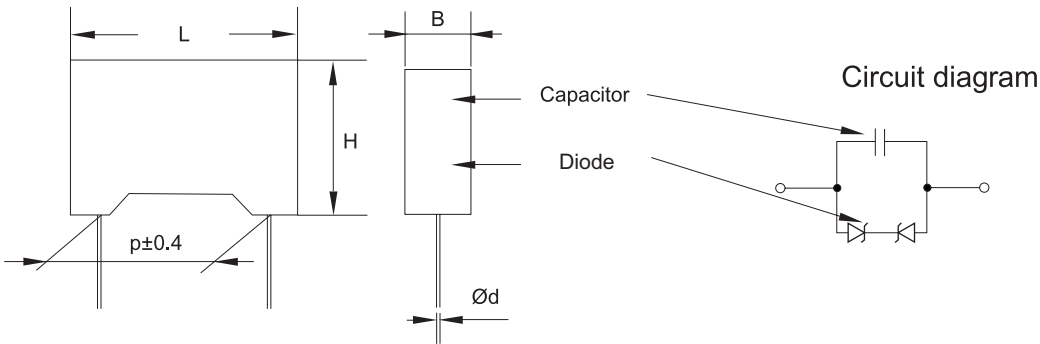

The F5B Series was designed for ambitious suppression demands and peak voltage limitation. Different operating and clamping voltages allow an optimal adaption to the different application requirements. Best results for suppression purposes are achieved by using low inductive MKT capacitors in parallel construction with bidirectional suppressor diode (TVS, Transient Voltage Suppressor) in one single case. The leaded EMI-RFI suppression element F5B is mainly prepared for Automotive applications without PC-board (e.g. motor suppression) or mixed leaded and SMD PC-boards. Upon customer's request there is also the possibility to create and deliver special versions.

#### PRODUCT CODE SYSTEM

The part number, comprising 14 digits, is formed as follows:

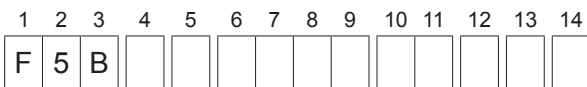

- Digit 1 to 3 Series code.
- Digit 4 d.c. Rated voltage:  
 A = 5V B = 18V H = 25V J = 30V  
 N = 45V C = 50V D = 63V
- Digit 5 Pitch (mm): C=5; F=10
- Digit 6 to 9 Digits 7 - 8 - 9 indicate the first three digits of Capacitance value and the 6th digit indicates the number of zeros that must be added to obtain the Rated Capacitance in pF.
- Digit 10 to 11 Mechanical version and/or packaging (Table 1)
- Digit 12 Nominal diode voltage (Table 2).
- Digit 13 Size code
- Digit 14 Capacitance tolerance:  
 J=5%; K=10%; M=20%.

#### GENERAL CHARACTERISTICS

- Capacitor:** metallized polyester film (MKT).
- Diode:** bidirectional Transient Voltage Suppressor Diode
- Protection:** plastic case, thermosetting resin filled. Box material is solvent resistant and flame retardant according to UL 94 V0.
- Leads:** tinned wire.
- Marking:** Manufacturer's logo (only pitch 10mm), series (F5B), capacitance, tolerance, D.C. rated voltage, manufacturing date code.

**Climatic category:** 55/125/56 IEC 60068-1  
**Operating temperature range:** -55 to +125°C  
 Table 1 Packaging

Standard packaging style	Lead length (mm)	Taping style			Ordering code (Digit 10 to 11)
		P <sub>2</sub> (mm)	Fig. (No)	Pitch (mm)	
AMMO-PACK		6.35	1	5	DQ
		1.27	2	10	DQ
REEL Ø 355mm		6.35	1	5	CK
		1.27	2	10	CK
Loose, short leads	4 <sup>+2</sup>				AA
Loose, long leads	17 <sup>+1/2</sup>				Z3

Other packaging styles are available upon request.

### METALLIZED POLYESTER FILM CAPACITOR WITH INTEGRATED BIDIRECTIONAL SUPPRESSOR DIODE HIGH PERFORMANCE PEAK REDUCTION

PRODUCT CODE: **F5B**

#### ELECTRICAL CHARACTERISTICS

**Capacitance range:** 100nF to 2.2μF  
**Capacitance values:** E12 series (IEC 60063 Norm).  
**Capacitance tolerance:** ±5% (J); ±10% (K); ±20% (M).  
**Rated voltage (V<sub>R</sub>):** 5Vdc - 18Vdc - 25Vdc - 30Vdc - 45Vdc - 50Vdc - 63Vdc

**Temperature derated voltage:**  
 for temperature over 100°C a decreasing factor of 2% per degree has to be applied on the rated voltage V<sub>R</sub>.  
**Breakdown Voltage (V<sub>BR</sub>):** see table 2, tolerance ±10%

**Diode Voltage range:** 10Vdc to 78Vdc

**Max Clamping voltage (V<sub>c</sub>) at max. Peak Current** :see Table 2

**Power dissipation (P<sub>max</sub>):** 600W (Pulse 10/700μs)

**Thermal Resistance:** see Table 3

**Leakage current (I<sub>dc</sub>):** ≤50μA @ V<sub>R</sub>

**Dissipation Factor (D.F.):**

tgδ x 10<sup>-4</sup> at 25°C ±5°C

kHz	tgδ x 10 <sup>-4</sup>
1	80
100	250

Table 2 Voltage and energy

Digit 4		Digit 12		600W type	
letter	V <sub>R</sub> (Vdc)	letter (600W type)	V <sub>BR</sub> (Vdc) @1mA	V <sub>Cmax</sub> (V)@Ip(A) 10/700μs	
A	5	E	10	14	37
		I	15	20	29
B	18	B	22	28	24
		E	27	33	31
H	25	A	30	36	20
		C	33	40	19
J	30	D	36	43	18
		I	39	46	17
		N	44	52	16
N	45	B	53	62	14
C	50	C	68	78	12
D	63	C	78	89	11

Table 3 Capacitance and size

Rated Cap. (μF)	R <sub>th</sub> (°C/W)	Size Code	Rated Voltage V <sub>R</sub>	Ød ±0.05	Size (Std dimensions)			
					B	H	L	p
0.1 to 1.2	82	7	5 to 63	0.6	6.0	11.0	7.2	5.0
1.5 to 2.2	73	8	5 to 50	0.6	7.2	13.0	7.2	5.0
0.1 to 1.5	64	3	5 to 63	0.7	6.0	12.0	13.0	10.0

All dimensions are in mm.

#### TEST METHOD AND PERFORMANCE

##### Damp heat, steady state:

###### Test conditions

Temperature: +40°C±2°C  
 Relative humidity (RH): 93% ±2%  
 Test duration: 56 days

###### Performance

Capacitance change |ΔC/C|: ≤5%  
 Breakdown voltage change: ≤10%  
 DF change (Δtgδ): ≤50x10<sup>-4</sup> @ 1kHz  
 Leakage current at V<sub>R</sub>: ≤100μA

##### Endurance:

###### Test conditions

Temperature: +125°C±2°C / 100°C±2°C  
 Voltage applied: 0.5xV<sub>R</sub> / 1.0xV<sub>R</sub>  
 Test duration: 1000 h

###### Performance

Capacitance change |ΔC/C|: ≤10%  
 Breakdown voltage change: ≤10%  
 DF change (Δtgδ): ≤50x10<sup>-4</sup> @ 1kHz  
 Leakage current at V<sub>R</sub>: ≤100μA

##### Resistance to soldering heat:

###### Test conditions

Temperature: +260°C±5°C  
 Test duration: 10±1s

###### Performance

Capacitance change |ΔC/C|: ≤3%  
 Breakdown voltage change: ≤5%  
 DF change (Δtgδ): ≤30x10<sup>-4</sup> @ 1kHz  
 Leakage current at V<sub>R</sub>: ≤50μA

##### Peak current derating:

###### Test conditions

Pulse 10/700μs, 300V<sub>p</sub>; 100 cycles with alternating polarity  
 Time between each current peak: 120s

###### Performance

Capacitance change |ΔC/C|: ≤10%  
 Breakdown voltage change: ≤10%  
 DF change (Δtgδ): ≤30x10<sup>-4</sup> @ 1kHz  
 Leakage current at V<sub>R</sub>: ≤100μA

##### Long term stability (after two years):

###### Test conditions

Temperature: -40°C to +80°C  
 Humidity: ≤70%

###### Performance

Capacitance change |ΔC/C|: ≤3%  
 Breakdown voltage change: ≤5%  
 DF change (Δtgδ): ≤20x10<sup>-4</sup> @ 1kHz  
 Leakage current at V<sub>R</sub>: ≤50μA

##### Reliability:

Reference MIL HDB 217

###### Application conditions:

Temperature: +40°C±2°C  
 Voltage: 0.5xV<sub>R</sub>  
 Failure rate: ≤3 FIT  
 (1FIT = 1x10<sup>-9</sup> failures/componentsxh)

###### Failure criteria:

Capacitance change |ΔC/C|: >10%  
 Breakdown voltage change: >10%  
 DF change (Δtgδ): >20x10<sup>-4</sup> @ 1kHz  
 Leakage current at V<sub>R</sub>: >200μA

**Warning: the component F5B is a protection and suppression combined passive component. Strong overloading (much higher energy, current or voltage) can strongly damage the component with the risk of explosion and fire.**

Statements of suitability for certain applications are based on our knowledge of typical operating conditions for such applications, but are not intended to constitute – and we specifically disclaim – any warranty concerning suitability for a specific customer application or use. This Information is intended for use only by customers who have the requisite experience and capability to determine the correct products for their application. Any technical advice inferred from this Information or otherwise provided by us with reference to the use of our products is given gratis, and we assume no obligation or liability for the advice given or results obtained.