

Ceramic Disc RFI Capacitors

3-digit lead style suffix codes -- Pick the **code** according to the **leadspacing** and desired **forming/taping**.

BULK PACKAGING						
	LEAD LENGTH L	LEAD DIA d	LEAD SPACING F			
			5mm	7.5mm	10mm	12.5mm
STRAIGHT LEADS	30 - 3mm	0.6mm	BF0	CF0	DF0	EF0
		0.8mm	BJ0	CJ0	DJ0	EJ0
	25 + 5mm	0.6mm	BY0	CY0	---	---
		0.8mm	BH0	CH0	DH0	EH0
	10 ± 1mm	0.6mm	BD0	CD0	DD0	ED0
6.0 + 0 - 1mm	0.6 / 0.8mm	BB0	CB0	DB0	EB0	
PREFORMED LEADS INSIDE CRIMP	30 - 3mm	0.6mm	BFG	CFG	DFG	EFG
		0.8mm	---	CJG	DJG	EJG
PREFORMED LEADS OUTSIDE CRIMP	5.0 ± 1mm	0.6mm	TA0	TC0	TE0	TG0
		0.8mm	---	TD0	TF0	TH0
PREFORMED LEADS SNAP-IN	min. 2.8mm	0.6mm	QA0	QC0	QE0	QG0
	min. 3.5mm	0.8mm	---	QD0	QF0	QH0

REEL PACKAGING						
COMPONENT PITCH 12.7mm LEAD DIAMETER 0.6mm	TAPING P H = 16.5		TAPING T H = 18.0mm / H ₀ = 16.0mm		TAPING U H = 20.0mm	
LEAD SPACING F	5mm	7.5mm	5mm	7.5mm	5mm	7.5mm
BODY DIAMETER D	valid for - 12mm STANDARD (> 12mm to - 13mm on request)					
STRAIGHT LEADS	BRE	CRE	BRA	CRA	BRC	CRC
PREFORMED LEADS INSIDE CRIMP	---	---	BRB	CRB	---	---
PERFORMED LEADS OUTSIDE CRIMP	---	---	TAR	TCR	---	---
PERFORMED LEADS 7.5mm to 5mm	---	---	UAR	---	---	---
PERFORMED LEADS SNAP-IN	---	---	QAR	QCR	---	---

REEL PACKAGING						
COMPONENT PITCH 25.4mm	TAPING F					
LEAD SPACING F			5mm	7.5mm	10mm	12.5mm
BODY DIAMETER D			> 12mm		ALL DIAMETERS	
STRAIGHT LEADS	H = 16.5mm		BRT	CRT	DRT	ERT
	H = 18.0mm		BRU	CRU	DRU	ERU
	H = 20.0mm		BRY	CRY	DRY	ERY
PREFORMED LEADS INSIDE CRIMP	H ₀ = 16.0mm		BRZ	CRZ	DRZ	ERZ

• The lead diameter of the taped components depends on the capacitance value and corresponds with the data given in the individual data sheets.

AMMO PACKAGING						
COMPONENT PITCH 12.7mm	TAPING P H = 16.5		TAPING T H = 18.0 / H ₀ = 16.0		TAPING U H = 20.0	
LEAD SPACING F	5mm	7.5mm	5mm	7.5mm	5mm	7.5mm
BODY DIAMETER D	Valid for - 12mm STANDARD (> 12mm to - 13mm on request)					
STRAIGHT LEADS	BLE	---	BLA	CLA	BLC	---
PREFORMED LEADS INSIDE CRIMP	---	---	BLB	---	---	---
PREFORMED LEADS 7.5mm to 5mm	---	---	UAL	---	---	---

Ceramic Disc RFI Capacitors

AVAILABLE STANDARD LEAD CONFIGURATIONS

STRAIGHT LEADS, LONG OR SHORT

$\varnothing d$	0.6 or 0.8			
L	30 - 3 or 10 ± 1			
F	5	7.5	10	12.5
e	max. 3.0mm			

The measurement position of Lead Spacing F and of Width V is critical in straight lead capacitors. The width V is not so critical in preformed lead capacitors.

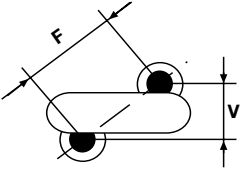
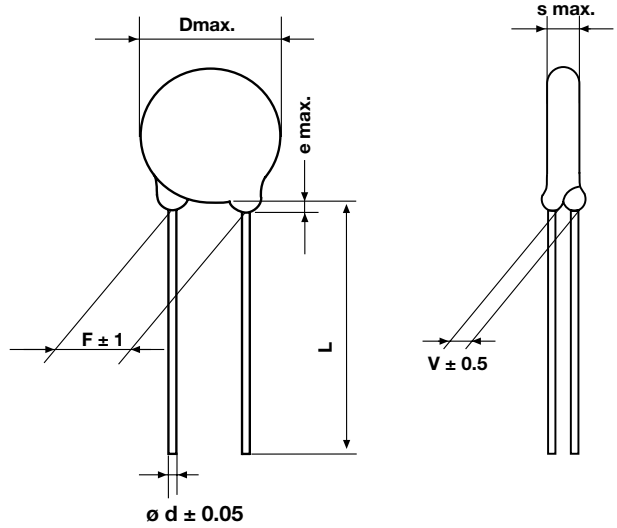
PREFORMED LEADS (INSIDE CRIMP)

$\varnothing d$	0.6 or 0.8			
F	5	7.5	10	12.5
A	$4.0 -1 + 0.5$	4.0 ± 1.5	5.0 ± 1.5	6.0 ± 1.5
L	min. 3.0mm			
Tolerance: 1.0mm absolute				

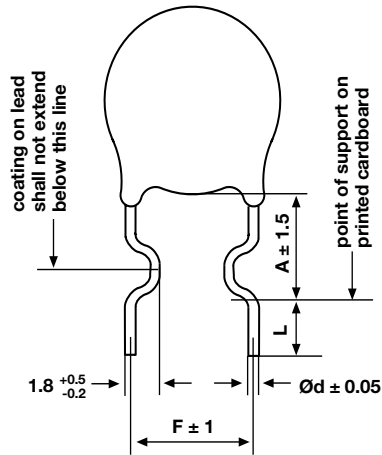

PREFORMED LEADS (OUTSIDE CRIMP)

$\varnothing d$	0.6	0.8	0.6 or 0.8		
F	5.0	7.5	7.5	10	12.5
A	5.0	5.0	6.0	6.0	6.0

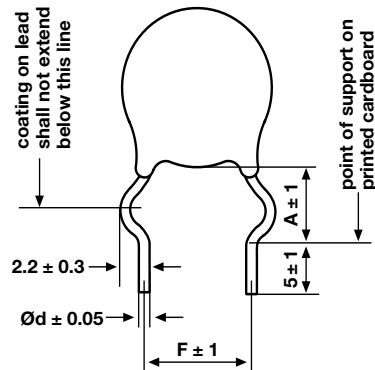

Ceramic Disc RFI Capacitors

PREFORMED LEADS (7.5 TO 5MM)

Ød	0.6
B	D - 9: 6.8 ± 0.7 D > 9: 7.5 ± 0.7
L	min. 2mm
	Tolerance 2mm absolute

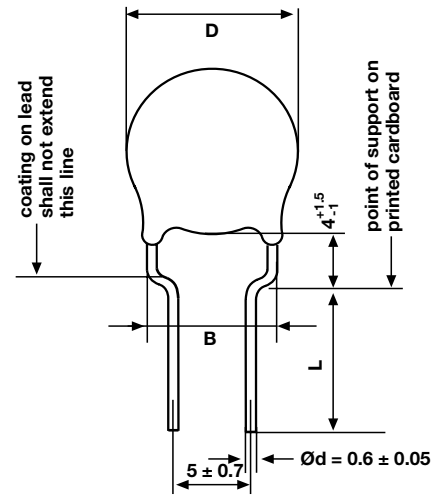

PREFORMED LEADS (DOUBLE CRIMP 'SNAP IN')

Ød	0.6	0.8
F	5.0 / 7.5 / 10 / 12.5	7.5 / 10 / 12.5
L	min. 2.8mm	min. 3.5mm
H	2.6	3.3
P1	1.25	1.65
P2	1.65	1.95
A	D - 8: 6.0 ± 1.5	D > 8: 7.0 ± 1.5

General Information: PCB max. thickness 1.6mm

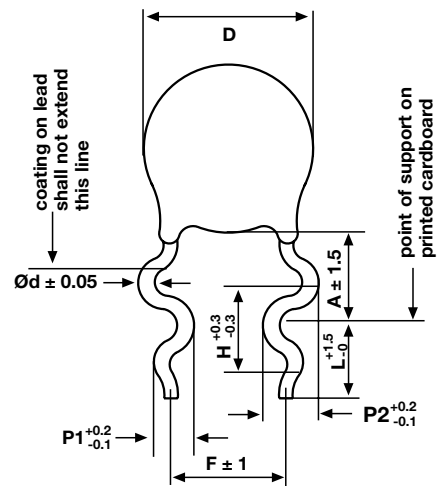

Ceramic Disc RFI Capacitors

RADIAL TAPING OF CERAMIC DISC CAPACITORS					
DESIGNATION	SYMBOL	TAPING P	TAPING T	TAPING U	TAPING F
Pitch of Component	P		12.7 ± 1		25.4 ± 1
Pitch of sprocket hole	P ₀		12.7 ± 0.3		12.7 ± 0.3
Distance, hole to lead	P ₁		3.85 ± 0.7		(0.5F) ± 0.7
Distance, hole to center of component	P ₂		6.35 ± 1.3		12.7 ± 1.3
Lead spacing	F		5.0 / 7.5 + 0.8 - 0.2		5/7.5/10/12.5 ± 0.8
Average deviation across tape	Δh		± 2.0 max.		± 3.0 max.
Average deviation in direction of reeling	ΔP		± 1.3 max.		± 1.3 max.
Carrier tape width	W		18.0 + 1 - 0.5		18.0 + 1 - 0.5
Hold-down tape width	W ₀		6.0		6.0
Position of sprocket hole	W ₁		9.0 + 0.75 - 0.5		9.0 + 0.75 - 0.5
Distance of hold-down tape	W ₂		3.0 max.		3.0 max.
Distance between the abscissa and the bottom plane of the component body	H	16.5 ± 0.5	18.0 + 2 - 0	20 ± 1	16.5 ± 0.5 18.0 + 2 - 0 20.0 ± 1
Distance between the abscissa and the reference plane of the component with crimped leads.	H ₀		16.0 ± 0.5		16.0 ± 0.5
Length of cut leads	L		11.0 max.		11.0 max.
Diameter of sprocket hole	D ₀		4.0 ± 0.2		4.0 ± 0.2
Total tape thickness	t		0.9 max.		0.9 max.

PACKAGING VERSIONS

Reel Packaging

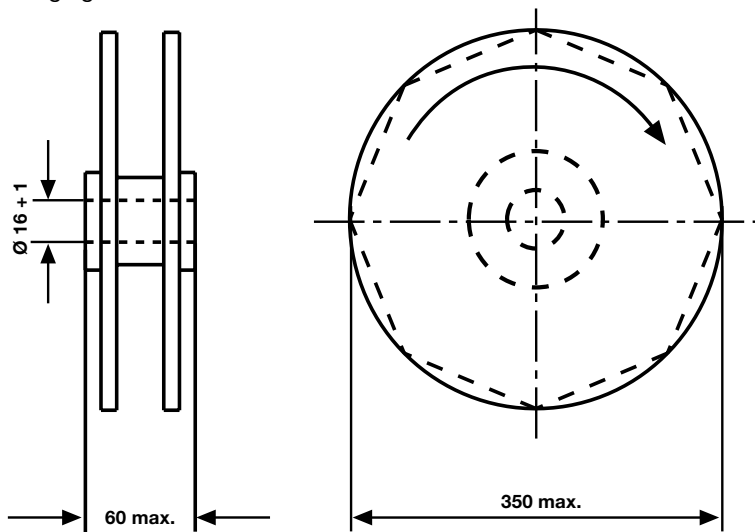

Ammo Packaging

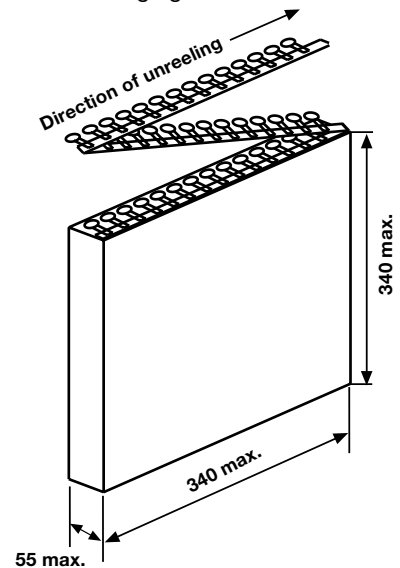

Ceramic Disc RFI Capacitors

TAPING P / T / U
COMPONENT PITCH 0.5 INCH
LEAD SPACING 5.0MM

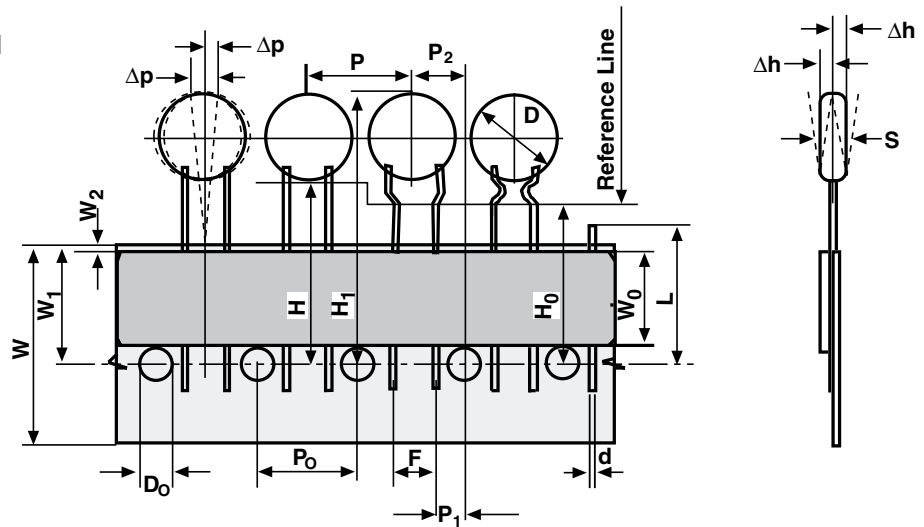

TAPING P / T / U
COMPONENT PITCH 0.5 INCH
LEAD SPACING 7.5MM

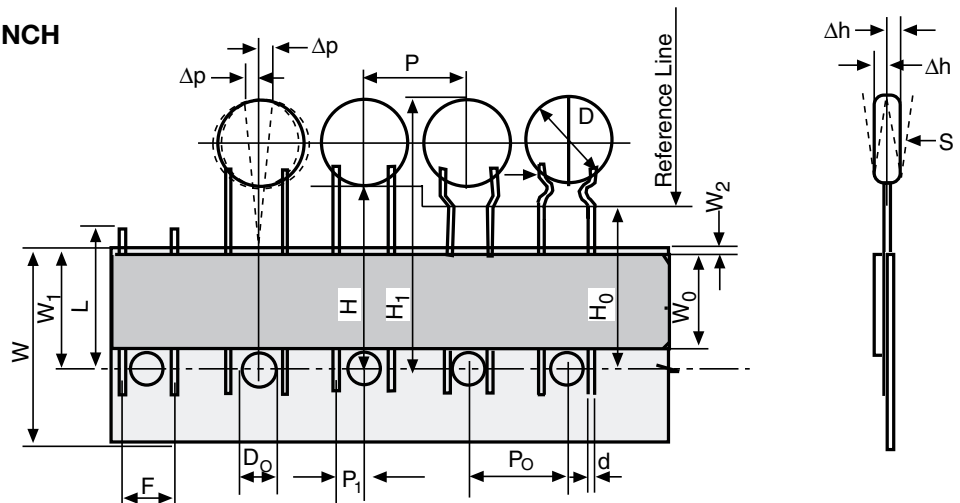

TAPING F
COMPONENT PITCH 1.0 INCH
LEAD SPACING 5.0 / 7.5 / 10 / 12.5MM

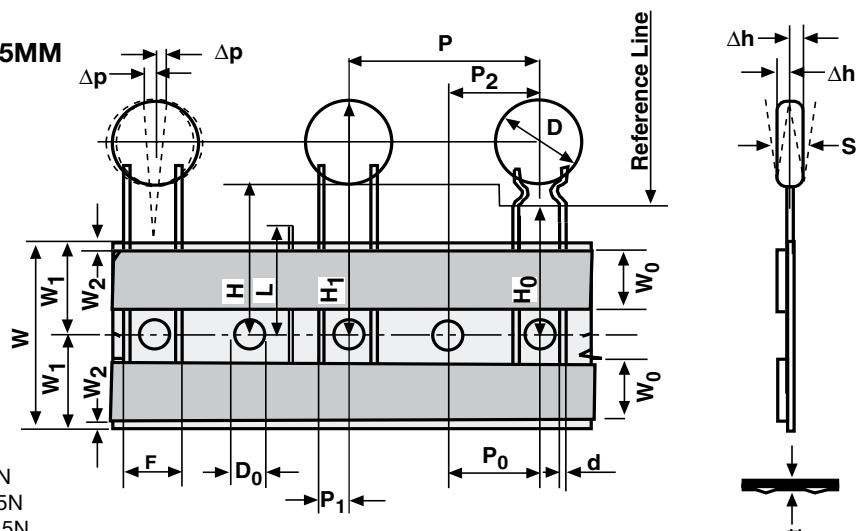

- Pulling force from the tape
- Tensile strength of tape
- Unreeling force of tape from reel
- 5N
- 15N
- 2.5N

Maximum 0.5% of all components on reel may be missing. A maximum of 3 consecutive components may be missing provided this gap is followed by 6 consecutive components. The splices shall have the same minimum strength as the tape. The splices must be not thicker than 1.5mm, the sprocket holes may not be effected.