

Overview

The KEMET T497 Series is designed for the COTS (Commercial Off-The-Shelf) requirements of military, medical, and aerospace applications. This product is a COTS version of CWR09, 19, and 29 products. The T497 Series is a surface mount product offering various lead-frame plating options, Weibull grading options, X-ray inspection, surge current testing, and other customer-defined testing options.

Benefits

- Established reliability options
- Taped and reeled per EIA 481-D
- Symmetrical, compliant terminations
- Laser-marked case
- 100% surge current test available on all case sizes
- Termination options B, H, and T
- Weibull failure options B and C
- Voltage rating of 4–50 VDC
- Operating temperature range of -55°C to +125°C
- Capacitance values of 0.1µF to 150µF
- 100% thermal shock

Applications

Typical applications include decoupling and filtering in military, medical, and aerospace applications.



Environmental Compliance

RoHS Compliant (6/6)* according to Directive 2002/95/EC

**When ordered with 100% Sn Solder*

SPICE

For a detailed analysis of specific part numbers, please visit kemet.com for a free download of KEMET's SPICE software. The KEMET SPICE program is freeware intended to aid design engineers in analyzing the performance of these capacitors over frequency, temperature, ripple, and DC bias conditions.

Ordering Information

T	497	G	226	K	020	A	H	6110
Capacitor Class	Series	Case Size	Capacitance Code (pF)	Capacitance Tolerance	Voltage	Failure Rate/ Design	Lead Material	Performance Options
T = Tantalum	High Grade COTS	A = 1005 B = 1505 C = 2005 D = 1510 E = 2010 F = 2214 G = 2711 H = 2915 X = 2824	First two digits represent significant figures. Third digit specifies number of zeros.	K = ±10% M = ±20%	004 = 4V 006 = 6.3V 010 = 10V 016 = 16V 020 = 20V 025 = 25V 035 = 35V 050 = 50V	A = N/A B = 0.1%/1000 hrs C = .01%/1000 hrs	T = 100% Matte Tin (Sn) Plated H = Standard Solder Coated (SnPb 5% Pb minimum) B = Gold Plated	6110 = Standard features 6115 = No surge, 100% X-ray, 6210 Surge = 10 cycles 25°C, 6215 Surge = 10 cycles 25°C, 100% X-ray 6410 Surge = 10 cycles -55°C and 85°C 6415 Surge = 10 cycles -55°C and 85°C, 100% X-ray

Performance Characteristics

Item	Performance Characteristics
Operating Temperature	-55°C to 125°C
Rated Capacitance Range	0.1µF–150µF @ 120 Hz/25°C
Capacitance Tolerance	K Tolerance (10%), M Tolerance (20%)
Rated Voltage Range	4V–50V
DF(120Hz)	Refer to Part Number Electrical Specification Table
ESR (100kHz)	Refer to Part Number Electrical Specification Table
Leakage Current	≤ 0.01CV (µA) at Rated Voltage after 5 minutes

Qualification

Test	Condition	Characteristics				
Endurance	105°C @ Rated Voltage, 2000 Hours 125°C @ 2/3 Rated Voltage, 2000 Hours	ΔC/C	Within -20%/+10% of initial value			
		DF	≤ Initial Limit			
		DCL	2 x IL @ 125°C			
		ESR	2 x Initial Limit			
Storage Life	125°C @ 0 Volts, 2000 Hour.	ΔC/C	Within -20%/+10% of initial value			
		DF	Within initial limits			
		DCL	Within 2.0 x initial limit			
		ESR	Within 2.0 x initial limit			
Humidity	85°C, 85% RH, 1000Hr, No Load	ΔC/C	Within -5%/+35% of initial value			
		DF	≤ Initial Limit			
		DCL	Within 3.0 x initial limit			
Temperature Stability	Extreme temperature exposure at a succession of continuous steps at +25°C, -55°C, +25°C, +85°C, +125°C, +25°C	+25°C	-55°C	+85°C	+125°C	
		ΔC/C	IL*	±20%	±20%	±30%
		DF	IL	IL	1.2 x IL	1.5 x IL
Surge Voltage	105°C, 1.32 x Rated Voltage 1000 cycles	DCL	IL			
		ESR	n/a			
		DCL	10 x IL			
		DCL	10 x IL			
Mechanical Shock/Vibration	MIL-Std-202, Meth. 213, Cond. I, 100G Peak MIL-Std-202, Meth. 204, Cond. D, 10Hz to 2000Hz, 20G Peak	ΔC/C	Within -20%/+10% of initial value			
		DF	Within initial limits			
		DCL	Within initial limits			

*IL = Initial Limit

Electrical Characteristics

ESR vs. Frequency

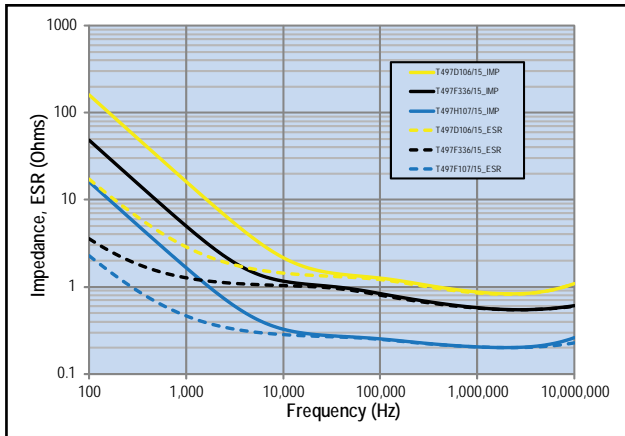

Capacitance vs. Frequency

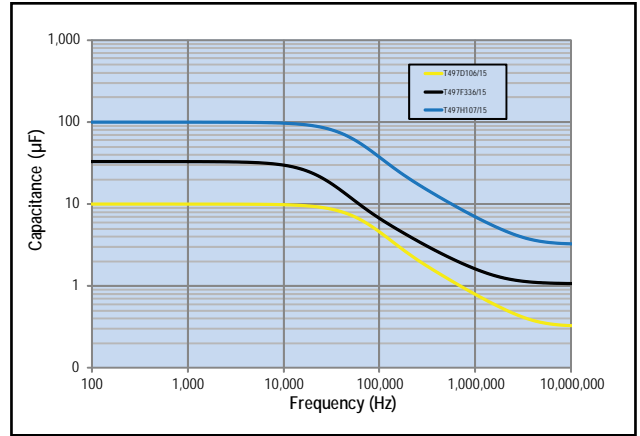

Dimensions – Millimeters (Inches)

Metric will govern

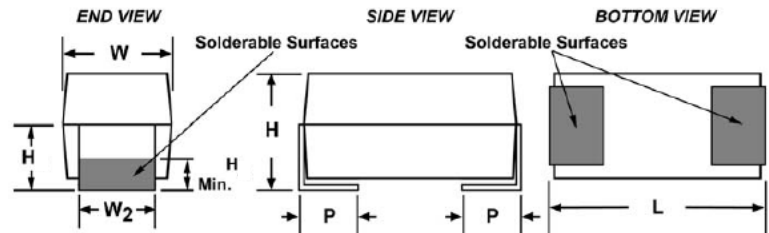

Case Size		Component			
KEMET	L* +/- 0.38 (.015)	W* +/- 0.38 (.015)	H* +/- 0.38 (.015)	P +.025(.010), -.13(.005)	W ₂
A	2.54 (.100)	1.27 (.050)	1.27 (.050)	0.76 (.030)	1.27 +/- 0.13 (.050 +/- .005)
B	3.81 (.150)	1.27 (.050)	1.27 (.050)	0.76 (.030)	1.27 +/- 0.13 (.050 +/- .005)
C	5.08 (.200)	1.27 (.050)	1.27 (.050)	0.76 (.030)	1.27 +/- 0.13 (.050 +/- .005)
D	3.81 (.150)	2.54 (.100)	1.27 (.050)	0.76 (.030)	2.41 +.13, -.25 (.095 +.005, -.010)
E	5.08 (.200)	2.54 (.100)	1.27 (.050)	0.76 (.030)	2.41 +.13, -.25 (.095 +.005, -.010)
F	5.59 (.220)	3.43 (.135)	1.78 (.070)	0.76 (.030)	3.30 +/- 0.13 (.130 +/- .005)
G	6.73 (.265)	2.79 (.110)	2.79 (.110)	1.27 (.050)	2.67 +/- 0.13 (.105 +/- .005)
H	7.24 (.285)	3.81 (.150)	2.79 (.110)	1.27 (.050)	3.68 +.013, -.051 (.145 +.005, -.020)
X	6.93 (.273)	5.41 (.213)	2.74 (.108)	1.19 (.047)	3.05 +/- 0.13 (.120 +/- .005)

Table 1 – Ratings & Part Number Reference

Rated Voltage	Rated Cap	Case Code/ Case Size	KEMET Part Number	DC Leakage	DF	ESR	Moisture Sensitivity
85°C VDC	120Hz µF	KEMET/EIA	(See below for part options)	µAmps +20°C max/5min	+20°C 120Hz % Max	+20°C 100kHz Ohms	Temp≤260°C J-STD-020D
4	4.7	A/1005	T497A475(1)004(2)(3)	0.2	6.0	12.0	1.0
4	4.7	B/1505	T497B475(1)004(2)(3)	0.2	6.0	8.0	1.0
4	15	B/1505	T497B156(1)004(2)(3)	0.6	8.0	8.0	1.0
4	33	D/1510	T497D336(1)004(2)(3)	1.3	8.0	4.0	1.0
4	33	F/2214	T497F336(1)004(2)(3)	1.3	8.0	2.2	1.0
4	68	E/2010	T497E686(1)004(2)(3)	2.7	8.0	3.0	1.0
4	68	F/2214	T497F686(1)004(2)(3)	2.7	6.0	2.0	1.0
4	68	G/2711	T497G686(1)004(2)(3)	2.7	10.0	1.1	1.0
4	100	H/2915	T497H107(1)004(2)(3)	4.0	10.0	0.9	1.0
6.3	1.5	A/1005	T497A155(1)006(2)(3)	0.1	6.0	8.0	1.0
6.3	2.2	A/1005	T497A225(1)006(2)(3)	0.1	6.0	10.0	1.0
6.3	3.3	A/1005	T497A335(1)006(2)(3)	0.2	6.0	12.0	1.0
6.3	3.3	B/1505	T497B335(1)006(2)(3)	0.2	6.0	8.0	1.0
6.3	4.7	A/1005	T497A475(1)006(2)(3)	0.3	6.0	12.0	1.0
6.3	4.7	D/1510	T497D475(1)006(2)(3)	0.3	6.0	5.5	1.0
6.3	6.8	B/1505	T497B685(1)006(2)(3)	0.4	6.0	8.0	1.0
6.3	6.8	D/1510	T497D685(1)006(2)(3)	0.4	6.0	4.5	1.0
6.3	10	B/1505	T497B106(1)006(2)(3)	0.6	6.0	8.0	1.0
6.3	10	E/2010	T497E106(1)006(2)(3)	0.6	8.0	3.5	1.0
6.3	15	B/1505	T497B156(1)006(2)(3)	0.9	8.0	8.0	1.0
6.3	15	D/1510	T497D156(1)006(2)(3)	0.9	8.0	5.0	1.0
6.3	22	D/1510	T497D226(1)006(2)(3)	1.4	6.0	5.0	1.0
6.3	22	E/2010	T497E226(1)006(2)(3)	1.4	8.0	3.5	1.0
6.3	22	F/2214	T497F226(1)006(2)(3)	1.4	8.0	2.2	1.0
6.3	33	E/2010	T497E336(1)006(2)(3)	2.1	6.0	3.5	1.0
6.3	47	F/2214	T497F476(1)006(2)(3)	3.0	8.0	3.5	1.0
6.3	47	G/2711	T497G476(1)006(2)(3)	3.0	10.0	1.1	1.0
6.3	68	F/2214	T497F686(1)006(2)(3)	4.3	10.0	1.5	1.0
6.3	68	H/2915	T497H686(1)006(2)(3)	4.3	10.0	0.9	1.0
6.3	100	G/2711	T497G107(1)006(2)(3)	6.3	10.0	1.1	1.0
6.3	150	G/2711	T497G157(1)006(2)(3)	9.5	10.0	1.1	1.0
6.3	150	H/2915	T497H157(1)006(2)(3)	9.5	10.0	0.9	1.0
10	0.47	A/1005	T497A474(1)010(2)(3)	0.0	6.0	10.0	1.0
10	1	A/1005	T497A105(1)010(2)(3)	0.1	6.0	10.0	1.0
10	1.5	A/1005	T497A155(1)010(2)(3)	0.2	6.0	10.0	1.0
10	2.2	A/1005	T497A225(1)010(2)(3)	0.2	6.0	12.0	1.0
10	2.2	B/1505	T497B225(1)010(2)(3)	0.2	6.0	8.0	1.0
10	3.3	A/1005	T497A335(1)010(2)(3)	0.3	6.0	12.0	1.0
10	3.3	B/1505	T497B335(1)010(2)(3)	0.3	6.0	10.0	1.0
10	4.7	B/1505	T497B475(1)010(2)(3)	0.5	6.0	8.0	1.0
10	4.7	D/1510	T497D475(1)010(2)(3)	0.5	6.0	4.5	1.0
10	6.8	B/1505	T497B685(1)010(2)(3)	0.7	6.0	8.0	1.0
10	6.8	F/2214	T497F685(1)010(2)(3)	0.7	6.0	5.0	1.0
10	6.8	E/2010	T497E685(1)010(2)(3)	0.7	6.0	3.5	1.0
10	10	B/1505	T497B106(1)010(2)(3)	1.0	8.0	8.0	1.0
10	10	D/1510	T497D106(1)010(2)(3)	1.0	6.0	4.0	1.0
10	10	E/2010	T497E106(1)010(2)(3)	1.0	6.0	3.5	1.0
10	15	D/1510	T497D156(1)010(2)(3)	1.5	6.0	5.0	1.0
VDC	µF	KEMET/EIA	(See below for part options)	max/5min	% Max	Ohms	J-STD-020A
85°C	120Hz			µAmps +20°C	+20°C 120Hz	+20°C 100kHz	Temp≤260°C
Rated Voltage	Rated Cap	Case Code/ Case Size	KEMET Part Number	DC Leakage	DF	ESR	Moisture Sensitivity

(1) To complete KEMET part number, insert M for ± 20% or K for ± 10%. Designates Capacitance tolerance.

(2) To complete KEMET part number, insert B (0.1%/1000Hrs), C (0.01%/1000Hrs) or A = N/A. Designates Reliability Level.

(3) To complete KEMET part number, insert T = 100% Matte Tin (Sn) Plated, B = Gold Plated, H = Standard Solder coated (SnPb 5% Pb minimum). Designates Termination Finish.

Refer to Ordering Information for additional detail.

Higher voltage ratings and tighter tolerance product including ESR may be substituted within the same size at KEMET's option. Voltage substitution will be marked with the higher voltage rating. Substitutions can include better than series.

Table 1 – Ratings & Part Number Reference con't

Rated Voltage	Rated Cap	Case Code/ Case Size	KEMET Part Number	DC Leakage	DF	ESR	Moisture Sensitivity
85°C VDC	120Hz µF	KEMET/EIA	(See below for part options)	µAmps +20°C max/5min	+20°C 120Hz % Max	+20°C 100kHz Ohms	Temp≤260°C J-STD-020D
10	15	E/2010	T497E156(1)010(2)(3)	1.5	8.0	3.0	1.0
10	15	F/2214	T497F156(1)010(2)(3)	1.5	8.0	2.5	1.0
10	22	D/1510	T497D226(1)010(2)(3)	2.2	6.0	4.0	1.0
10	22	E/2010	T497E226(1)010(2)(3)	2.2	8.0	2.0	1.0
10	22	F/2214	T497F226(1)010(2)(3)	2.2	8.0	1.5	1.0
10	22	G/2711	T497G226(1)010(2)(3)	2.2	8.0	1.5	1.0
10	33	F/2214	T497F336(1)010(2)(3)	3.3	8.0	1.5	1.0
10	33	G/2711	T497G336(1)010(2)(3)	3.3	10.0	1.5	1.0
10	47	F/2214	T497F476(1)010(2)(3)	4.7	10.0	1.5	1.0
10	47	G/2711	T497G476(1)010(2)(3)	4.7	10.0	1.0	1.0
10	47	H/2915	T497H476(1)010(2)(3)	4.7	10.0	0.9	1.0
10	68	G/2711	T497G686(1)010(2)(3)	6.8	10.0	1.1	1.0
10	100	G/2711	T497G107(1)010(2)(3)	10.0	10.0	1.1	1.0
10	100	H/2915	T497H107(1)010(2)(3)	10.0	10.0	0.9	1.0
10	150	H/2915	T497H157(1)010(2)(3)	15.0	10.0	0.9	1.0
15	0.1	A/1005	T497A104(1)015(2)(3)	0.0	6.0	15.0	1.0
15	0.22	A/1005	T497A224(1)015(2)(3)	0.0	6.0	15.0	1.0
15	0.33	A/1005	T497A334(1)015(2)(3)	0.0	6.0	15.0	1.0
15	0.68	A/1005	T497A684(1)015(2)(3)	0.1	6.0	20.0	1.0
15	1	A/1005	T497A105(1)015(2)(3)	0.2	6.0	15.0	1.0
15	1.5	A/1005	T497A155(1)015(2)(3)	0.2	6.0	15.0	1.0
15	1.5	B/1505	T497B155(1)015(2)(3)	0.2	6.0	8.0	1.0
15	2.2	A/1005	T497A225(1)015(2)(3)	0.3	6.0	15.0	1.0
15	3.3	B/1505	T497B335(1)015(2)(3)	0.5	6.0	9.0	1.0
15	3.3	D/1510	T497D335(1)015(2)(3)	0.5	6.0	5.0	1.0
15	4.7	B/1505	T497B475(1)015(2)(3)	0.7	6.0	5.0	1.0
15	4.7	D/1510	T497D475(1)015(2)(3)	0.7	6.0	6.0	1.0
15	4.7	E/2010	T497E475(1)015(2)(3)	0.7	6.0	4.0	1.0
15	6.8	D/1510	T497D685(1)015(2)(3)	1.0	6.0	6.0	1.0
15	10	D/1510	T497D106(1)015(2)(3)	1.5	6.0	6.0	1.0
15	10	E/2010	T497E106(1)015(2)(3)	1.5	6.0	4.0	1.0
15	10	F/2214	T497F106(1)015(2)(3)	1.5	6.0	2.5	1.0
15	15	E/2010	T497E156(1)015(2)(3)	2.3	6.0	4.0	1.0
15	15	F/2214	T497F156(1)015(2)(3)	2.3	6.0	2.5	1.0
15	22	F/2214	T497F226(1)015(2)(3)	3.3	8.0	3.0	1.0
15	22	G/2711	T497G226(1)015(2)(3)	3.3	6.0	1.1	1.0
15	33	F/2214	T497F336(1)015(2)(3)	5.0	6.0	3.0	1.0
15	33	H/2915	T497H336(1)015(2)(3)	5.0	8.0	0.9	1.0
15	47	G/2711	T497G476(1)015(2)(3)	7.1	8.0	1.1	1.0
15	68	H/2915	T497H686(1)015(2)(3)	10.2	8.0	0.9	1.0
15	100	H/2915	T497H107(1)015(2)(3)	15.0	10.0	0.9	1.0
20	0.15	A/1005	T497A154(1)020(2)(3)	0.0	8.0	15.0	1.0
20	0.47	A/1005	T497A474(1)020(2)(3)	0.1	8.0	14.0	1.0
20	0.68	A/1005	T497A684(1)020(2)(3)	0.1	6.0	15.0	1.0
20	0.68	B/1505	T497B684(1)020(2)(3)	0.1	6.0	10.0	1.0
20	1	A/1005	T497A105(1)020(2)(3)	0.2	6.0	15.0	1.0
20	1	B/1505	T497B105(1)020(2)(3)	0.2	6.0	12.0	1.0
20	1.5	B/1505	T497B155(1)020(2)(3)	0.3	6.0	9.0	1.0
VDC	µF	KEMET/EIA	(See below for part options)	max/5min	% Max	Ohms	J-STD-020A
85°C	120Hz			µAmps +20°C	+20°C 120Hz	+20°C 100kHz	Temp≤260°C
Rated Voltage	Rated Cap	Case Code/ Case Size	KEMET Part Number	DC Leakage	DF	ESR	Moisture Sensitivity

(1) To complete KEMET part number, insert M for ± 20% or K for ± 10%. Designates Capacitance tolerance.

(2) To complete KEMET part number, insert B (0.1%/1000Hrs), C (0.01%/1000Hrs) or A = N/A. Designates Reliability Level.

(3) To complete KEMET part number, insert T = 100% Matte Tin (Sn) Plated, B = Gold Plated, H = Standard Solder coated (SnPb 5% Pb minimum). Designates Termination Finish.

Refer to Ordering Information for additional detail.

Higher voltage ratings and tighter tolerance product including ESR may be substituted within the same size at KEMET's option. Voltage substitution will be marked with the higher voltage rating. Substitutions can include better than series.

Table 1 – Ratings & Part Number Reference con't

Rated Voltage	Rated Cap	Case Code/ Case Size	KEMET Part Number	DC Leakage	DF	ESR	Moisture Sensitivity
85°C VDC	120Hz µF	KEMET/EIA	(See below for part options)	µAmps +20°C max/5min	+20°C 120Hz % Max	+20°C 100kHz Ohms	Temp≤260°C J-STD-020D
20	2.2	B/1505	T497B225(1)020(2)(3)	0.4	6.0	9.0	1.0
20	2.2	D/1510	T497D225(1)020(2)(3)	0.4	6.0	5.0	1.0
20	3.3	D/1510	T497D335(1)020(2)(3)	0.7	6.0	6.0	1.0
20	3.3	E/2010	T497E335(1)020(2)(3)	0.7	6.0	4.0	1.0
20	4.7	E/2010	T497E475(1)020(2)(3)	0.9	6.0	6.0	1.0
20	4.7	F/2214	T497F475(1)020(2)(3)	0.9	6.0	4.0	1.0
20	6.8	D/1510	T497D685(1)020(2)(3)	1.4	6.0	5.0	1.0
20	6.8	E/2010	T497E685(1)020(2)(3)	1.4	6.0	5.0	1.0
20	6.8	F/2214	T497F685(1)020(2)(3)	1.4	6.0	2.4	1.0
20	10	F/2214	T497F106(1)020(2)(3)	2.0	6.0	3.0	1.0
20	15	F/2214	T497F156(1)020(2)(3)	3.0	6.0	3.0	1.0
20	15	G/2711	T497G156(1)020(2)(3)	3.0	6.0	1.1	1.0
20	22	G/2711	T497G226(1)020(2)(3)	4.4	6.0	2.5	1.0
20	22	H/2915	T497H226(1)020(2)(3)	4.4	6.0	0.9	1.0
20	33	H/2915	T497H336(1)020(2)(3)	6.6	8.0	0.9	1.0
20	47	H/2915	T497H476(1)020(2)(3)	9.4	8.0	0.9	1.0
25	0.33	A/1005	T497A334(1)025(2)(3)	0.1	6.0	15.0	1.0
25	0.47	A/1005	T497A474(1)025(2)(3)	0.1	6.0	15.0	1.0
25	0.68	B/1505	T497B684(1)025(2)(3)	0.2	6.0	7.5	1.0
25	1	B/1505	T497B105(1)025(2)(3)	0.3	6.0	10.0	1.0
25	1	C/2005	T497C105(1)025(2)(3)	0.3	6.0	6.5	1.0
25	1.5	D/1510	T497D155(1)025(2)(3)	0.4	6.0	6.5	1.0
25	2.2	D/1510	T497D225(1)025(2)(3)	0.6	6.0	6.0	1.0
25	2.2	E/2010	T497E225(1)025(2)(3)	0.6	6.0	3.5	1.0
25	3.3	E/2010	T497E335(1)025(2)(3)	0.8	6.0	4.0	1.0
25	4.7	F/2214	T497F475(1)025(2)(3)	1.2	6.0	2.5	1.0
25	6.8	F/2214	T497F685(1)025(2)(3)	1.7	6.0	3.0	1.0
25	6.8	G/2711	T497G685(1)025(2)(3)	1.7	6.0	1.2	1.0
25	10	F/2214	T497F106(1)025(2)(3)	2.5	6.0	2.5	1.0
25	10	G/2711	T497G106(1)025(2)(3)	2.5	6.0	1.4	1.0
25	15	G/2711	T497G156(1)025(2)(3)	3.8	6.0	1.4	1.0
25	15	H/2915	T497H156(1)025(2)(3)	3.8	6.0	1.0	1.0
25	22	G/2711	T497G226(1)025(2)(3)	5.5	6.0	1.4	1.0
25	22	H/2915	T497H226(1)025(2)(3)	5.5	6.0	0.9	1.0
25	22	X/2824	T497X226(1)025(2)(3)	5.5	6.0	0.9	1.0
25	33	H/2915	T497H336(1)025(2)(3)	8.3	8.0	0.9	1.0
25	33	X/2824	T497X336(1)025(2)(3)	8.3	8.0	0.9	1.0
35	0.22	A/1005	T497A224(1)035(2)(3)	0.1	6.0	18.0	1.0
35	0.33	A/1005	T497A334(1)035(2)(3)	0.1	6.0	22.0	1.0
35	0.47	B/1505	T497B474(1)035(2)(3)	0.2	6.0	10.0	1.0
35	0.68	C/2005	T497C684(1)035(2)(3)	0.2	6.0	8.0	1.0
35	1	D/1510	T497D105(1)035(2)(3)	0.4	6.0	6.5	1.0
35	1.5	E/2010	T497E155(1)035(2)(3)	0.5	6.0	4.5	1.0
35	3.3	F/2214	T497F335(1)035(2)(3)	1.2	6.0	2.5	1.0
35	4.7	G/2711	T497G475(1)035(2)(3)	1.6	6.0	1.5	1.0
35	6.8	G/2711	T497G685(1)035(2)(3)	2.4	6.0	1.3	1.0
35	6.8	H/2915	T497H685(1)035(2)(3)	2.4	6.0	1.3	1.0
35	10	H/2915	T497H106(1)035(2)(3)	3.5	8.0	0.9	1.0
VDC	µF	KEMET/EIA	(See below for part options)	max/5min	% Max	Ohms	J-STD-020A
85°C	120Hz			µAmps +20°C	+20°C 120Hz	+20°C 100kHz	Temp≤260°C
Rated Voltage	Rated Cap	Case Code/ Case Size	KEMET Part Number	DC Leakage	DF	ESR	Moisture Sensitivity

(1) To complete KEMET part number, insert M for ± 20% or K for ± 10%. Designates Capacitance tolerance.

(2) To complete KEMET part number, insert B (0.1%/1000Hrs), C (0.01%/1000Hrs) or A = N/A. Designates Reliability Level.

(3) To complete KEMET part number, insert T = 100% Matte Tin (Sn) Plated, B = Gold Plated, H = Standard Solder coated (SnPb 5% Pb minimum). Designates Termination Finish.

Refer to Ordering Information for additional detail.

Higher voltage ratings and tighter tolerance product including ESR may be substituted within the same size at KEMET's option. Voltage substitution will be marked with the higher voltage rating. Substitutions can include better than series.

Table 1 – Ratings & Part Number Reference con't

Rated Voltage	Rated Cap	Case Code/ Case Size	KEMET Part Number	DC Leakage	DF	ESR	Moisture Sensitivity
85°C VDC	120Hz µF	KEMET/EIA	(See below for part options)	µAmps +20°C max/5min	+20°C 120Hz % Max	+20°C 100kHz Ohms	Temp≤260°C J-STD-020D
35	15	X/2824	T497X156(1)035(2)(3)	5.3	6.0	0.9	1.0
50	0.1	A/1005	T497A104(1)050(2)(3)	0.1	6.0	22.0	1.0
50	0.15	A/1005	T497A154(1)050(2)(3)	0.1	6.0	17.0	1.0
50	0.22	B/1505	T497B224(1)050(2)(3)	0.1	6.0	14.0	1.0
50	0.33	B/1505	T497B334(1)050(2)(3)	0.2	6.0	12.0	1.0
50	0.47	C/2005	T497C474(1)050(2)(3)	0.2	6.0	8.0	1.0
50	0.68	D/1510	T497D684(1)050(2)(3)	0.3	6.0	7.0	1.0
50	1	E/2010	T497E105(1)050(2)(3)	0.5	6.0	6.0	1.0
50	1.5	F/2214	T497F155(1)050(2)(3)	0.8	6.0	4.0	1.0
50	2.2	F/2214	T497F225(1)050(2)(3)	1.1	6.0	2.5	1.0
50	3.3	G/2711	T497G335(1)050(2)(3)	1.7	6.0	2.0	1.0
50	4.7	H/2915	T497H475(1)050(2)(3)	2.4	6.0	1.5	1.0
VDC 85°C	µF 120Hz	KEMET/EIA	(See below for part options)	max/5min µAmps +20°C	% Max +20°C 120Hz	Ohms +20°C 100kHz	J-STD-020A Temp≤260°C
Rated Voltage	Rated Cap	Case Code/ Case Size	KEMET Part Number	DC Leakage	DF	ESR	Moisture Sensitivity

(1) To complete KEMET part number, insert M for ± 20% or K for ± 10%. Designates Capacitance tolerance.

(2) To complete KEMET part number, insert B (0.1%/1000Hrs), C (0.01%/1000Hrs) or A = N/A. Designates Reliability Level.

(3) To complete KEMET part number, insert T = 100% Matte Tin (Sn) Plated, B = Gold Plated, H = Standard Solder coated (SnPb 5% Pb minimum). Designates Termination Finish.

Refer to Ordering Information for additional detail.

Higher voltage ratings and tighter tolerance product including ESR may be substituted within the same size at KEMET's option. Voltage substitution will be marked with the higher voltage rating. Substitutions can include better than series.

Recommended Voltage Derating Guidelines

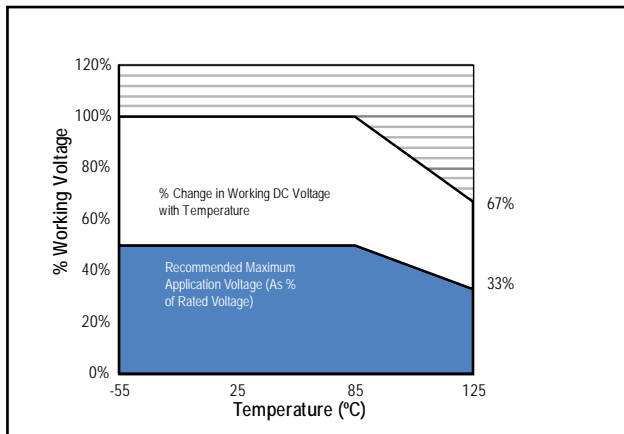

Ripple Current/Ripple Voltage

Case Code		Maximum Power Dissipation (Pmax) mWatts @ 25°C w/+20°C Rise
KEMET	EIA	
A	1005	50
B	1505	70
C	2005	75
D	1510	80
E	2010	90
F	2214	100
G	2711	125
H	2915	150

Temperature Compensation Multipliers for Maximum Power Dissipation		
≤25°C	85°C	125°C
1.00	0.90	0.40

T = Environmental Temperature

Using the P max of the device, the maximum allowable rms ripple current or voltage may be determined.

$$I(max) = \sqrt{P_{max}/R}$$

$$E(max) = \sqrt{P_{max} \cdot R}$$

I = rms ripple current (amperes)

E = rms ripple voltage (volts)

*P*_{max} = maximum power dissipation(watts)

R = ESR at specified frequency (ohms)

Reverse Voltage

Solid tantalum capacitors are polar devices and may be permanently damaged or destroyed if connected with the wrong polarity. The positive terminal is identified on the capacitor body by a stripe plus in some cases a beveled edge. A small degree of transient reverse voltage is permissible for short periods per the table. The capacitors should not be operated continuously in reverse mode, even within these limits.

Temperature	Permissible Transient Reverse Voltage
25°C	15% of Rated Voltage
85°C	5% of Rated Voltage
125°C	1% of Rated Voltage

Table 2 – Land Dimensions/Courtyard

KEMET	Metric Size Code	Density Level A: Maximum (Most) Land Protrusion (mm)					Density Level B: Median (Nominal) Land Protrusion (mm)					Density Level C: Minimum (Least) Land Protrusion (mm)						
		Case	EIA	X	Y	C	V1	V2	X	Y	C	V1	V2	X	Y	C	V1	V2
		A ¹	1005	1.45	2.15	1.20	5.60	2.70	1.35	1.85	1.05	4.50	2.20	1.25	1.55	0.90	3.60	1.90
		B	1505	1.45	2.30	1.75	6.80	2.70	1.35	1.90	1.65	5.70	2.20	1.25	1.55	1.55	4.90	1.92
		C	2005	1.45	2.30	2.40	8.10	2.70	1.35	1.90	2.30	7.00	2.20	1.25	1.55	2.15	6.10	1.90
		D	1510	2.60	2.30	1.75	6.80	4.00	2.45	1.90	1.65	5.70	3.50	2.35	1.55	1.55	4.90	3.20
		E	2010	2.60	2.30	2.40	8.10	4.00	2.45	1.90	2.30	7.00	3.50	2.35	1.55	2.15	6.10	3.20
		F	2214	3.50	2.30	2.65	8.60	4.90	3.35	1.90	2.55	7.50	4.40	3.25	1.55	2.45	6.70	4.10
		G	2711	2.85	2.80	2.95	9.70	4.20	2.75	2.40	2.85	8.60	3.70	2.65	2.05	2.75	7.80	3.40
		H	2915	3.85	2.80	3.20	10.20	5.20	3.75	2.40	3.10	9.10	4.70	3.65	2.05	3.00	8.30	4.40
		X	2824	3.25	2.75	3.10	10.00	6.80	3.10	2.35	3.00	8.90	6.30	3.00	1.95	2.90	8.00	6.00

Density Level A: For low-density Product applications. Recommended for wave solder applications and provides a wider process window for reflow solder processes.

Density Level B: For products with a moderate level of component density. Provides a robust solder attachment condition for reflow solder processes.

Density Level C: For high component density product applications. Before adapting the minimum land pattern variations the user should perform qualification testing based on the conditions outlined in IPC standard 7351 (IPC-7351).

¹ Land pattern geometry is too small for silkscreen outline.

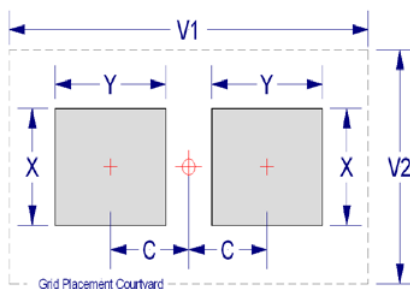

Soldering Process

KEMET's families of surface mount capacitors are compatible with wave (single or dual), convection, IR or vapor phase reflow techniques. Preheating of these components is recommended to avoid extreme thermal stress. KEMET's recommended profile conditions for convection and IR reflow reflect the profile conditions of the IPC/J-STD-020D standard for moisture sensitivity testing. The devices can safely withstand a maximum of three reflow passes at these conditions.

Note that although the X/7343-43 case size can withstand wave soldering, the tall profile (4.3 mm maximum) dictates care in wave process development.

Hand soldering should be performed with care due to the difficulty in process control. If performed, care should be taken to avoid contact of the soldering iron to the molded case. The iron should be used to heat the solder pad, applying solder between the pad and the termination, until reflow occurs. Once reflow occurred, the iron should be removed immediately. "Wiping" the edges of a chip and heating the top surface is not recommended.

During typical reflow operations, a slight darkening of the gold-colored epoxy may be observed. This slight darkening is normal and is not harmful to the product. Marking permanency is not affected by this change.

Profile Feature	SnPb Assembly	Pb-Free Assembly
Preheat/Soak		
Temperature Min (T_{Smin})	100°C	150°C
Temperature Max (T_{Smax})	150°C	200°C
Time (t_s) from T_{Smin} to T_{Smax}	60–120 sec	60–120 sec
Ramp-up Rate (T_L to T_p)	3°C/sec max	3°C/sec max
Liquidous Temperature (T_L)	183°C	217°C
Time Above Liquidous (t_L)	60–150 sec	60–150 sec
Peak Temperature (T_p)	220°C* 235°C**	250°C* 260°C**
Time within 5°C of Max Peak Temperature (t_p)	20 sec max	30 sec max
Ramp-down Rate (T_p to T_L)	6°C/sec max	6°C/sec max
Time 25°C to Peak Temperature	6 minutes max	8 minutes max

Note: All temperatures refer to the center of the package, measured on the package body surface that is facing up during assembly reflow.

*Case Size D, E, P, Y and X

**Case Size A, B, C, H, I, K, M, R, S, T, U, V, W and Z

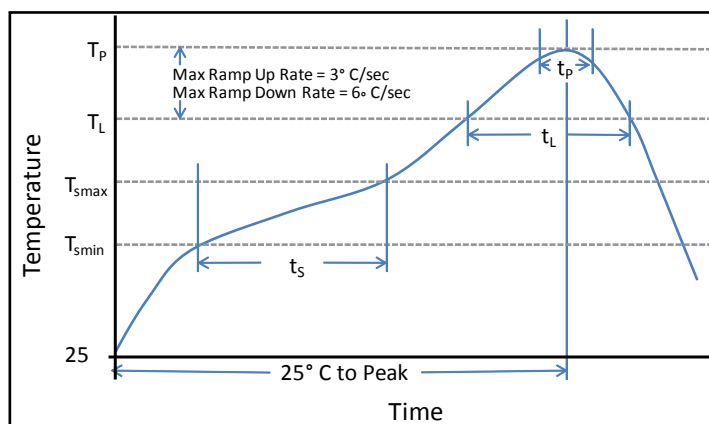

Construction

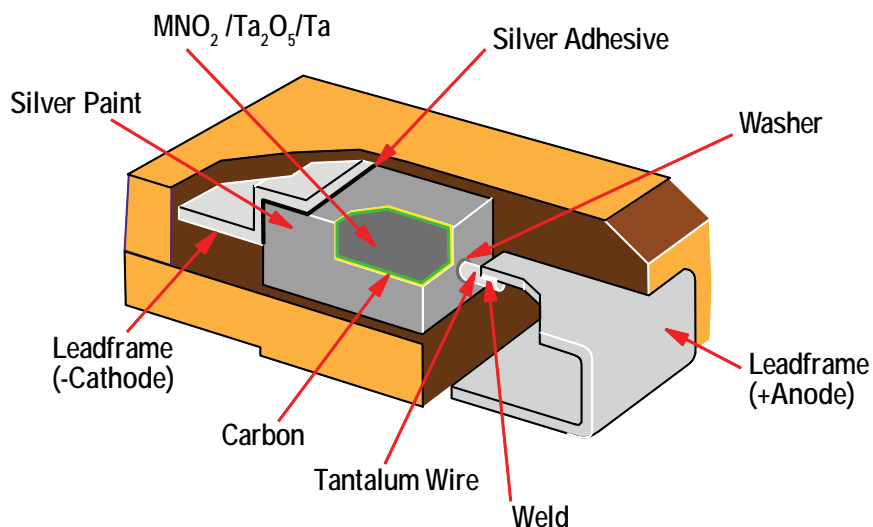

Capacitor Marking

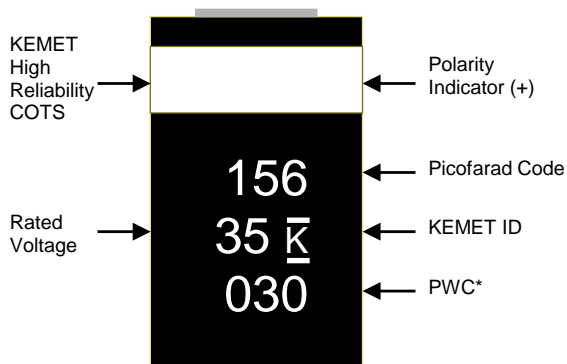

* 030 = 30th week of 2010

Storage

Tantalum chip capacitors should be stored in normal working environments. While the chips themselves are quite robust in other environments, solderability will be degraded by exposure to high temperatures, high humidity, corrosive atmospheres, and long term storage. In addition, packaging materials will be degraded by high temperature - reels may soften or warp, and tape peel force may increase. KEMET recommends that maximum storage temperature not exceed 40°C, and maximum storage humidity not exceed 60% relative humidity. In addition, temperature fluctuations should be minimized to avoid condensation on the parts, and atmospheres should be free of chlorine and sulphur bearing compounds. For optimized solderability, chip stock should be used promptly, preferably within three years of receipt.

Tape & Reel Packaging Information

KEMET's Molded Tantalum and Aluminum Chip Capacitor families are packaged in 8 mm and 12 mm plastic tape on 7" and 13" reels, in accordance with EIA Standard 481-D: Taping of Surface Mount Components for Automatic Handling. This packaging system is compatible with all tape fed automatic pick and place systems.

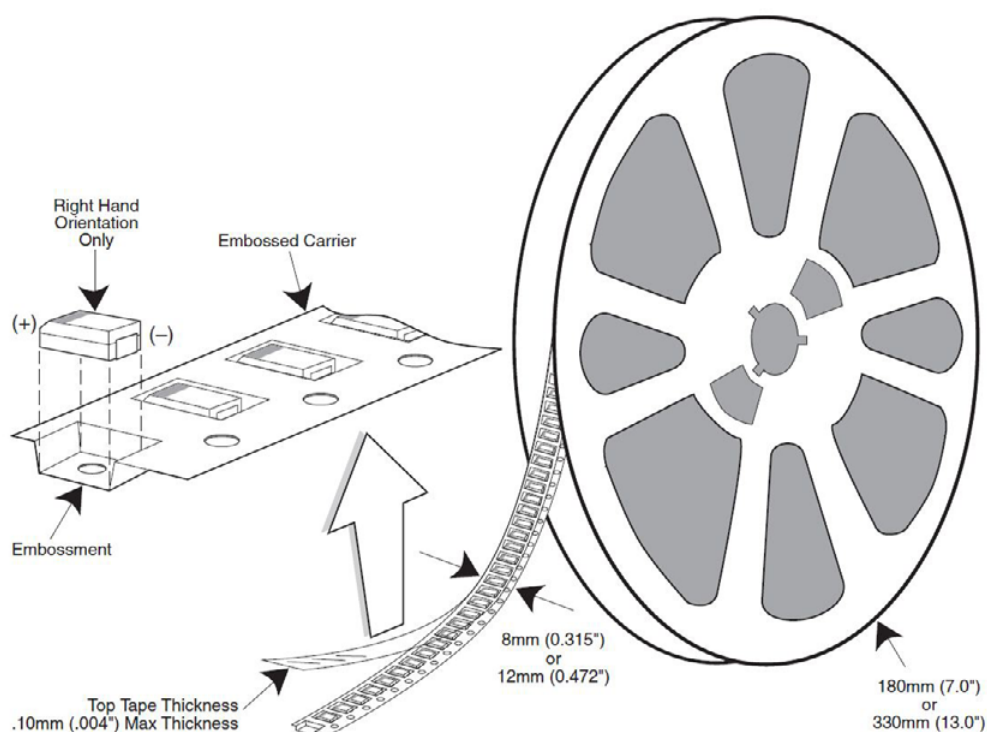

Table 3 – Packaging Quantity

Case Code		Tape Width-mm	7" Reel*	13" Reel*
KEMET	EIA			
R	2012-12	8	2,500	10,000
I	3216-10	8	3,000	12,000
S	3216-12	8	2,500	10,000
T	3528-12	8	2,500	10,000
M	3528-15	8	2,000	8,000
U	6032-15	12	1,000	5,000
L	6032-19	12	1,000	5,000
W	7343-15	12	1,000	3,000
Z	7343-17	12	1,000	3,000
V	7343-20	12	1,000	3,000
A	3216-18	8	2,000	9,000
B	3528-21	8	2,000	8,000
C	6032-28	12	500	3,000
D	7343-31	12	500	2,500
Y	7343-40	12	500	2,000
X	7343-43	12	500	2,000
E	7260-38	12	500	2,000

* No c-spec required for 7" reel packaging. C-7280 required for 13" reel packaging.

Figure 1 – Embossed (Plastic) Carrier Tape Dimensions

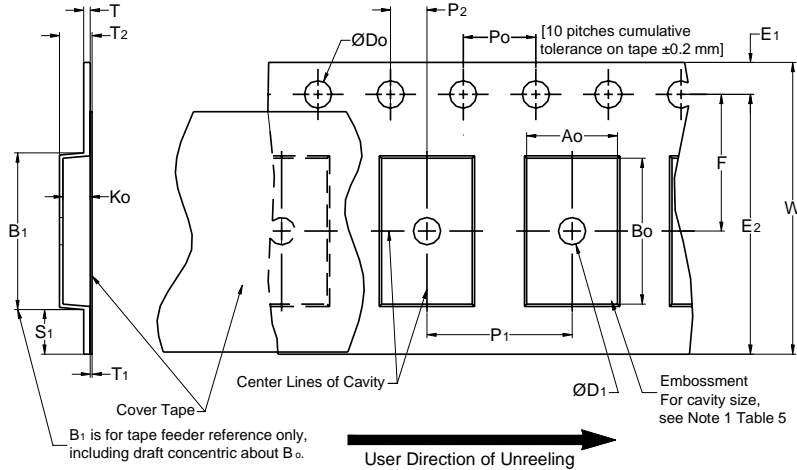

Table 4 – Embossed (Plastic) Carrier Tape Dimensions

Metric will govern

Constant Dimensions — Millimeters (Inches)									
Tape Size	D ₀	D ₁ Min. Note 1	E ₁	P ₀	P ₂	R Ref. Note 2	S ₁ Min. Note 3	T Max.	T ₁ Max.
8mm	1.5 +0.10/-0.0 (0.059 +0.004/-0.0)	1.0 (0.039)	1.75 ± 0.10 (0.069 ± 0.004)	4.0 ± 0.10 (0.157 ± 0.004)	2.0 ± 0.05 (0.079 ± 0.002)	25.0 (0.984)	0.600 (0.024)	0.600 (0.024)	0.100 (0.004)
12mm		1.5 (0.059)				30 (1.181)			
16mm									
Variable Dimensions — Millimeters (Inches)									
Tape Size	Pitch	B ₁ Max. Note 4	E ₂ Min.	F	P ₁	T ₂ Max	W Max	A ₀ , B ₀ & K ₀	
8mm	Single (4mm)	4.35 (0.171)	6.25 (0.246)	3.5 ± 0.05 (0.138 ± 0.002)	4.0 ± 0.10 (0.157 ± 0.004)	2.5 (0.098)	8.3 (0.327)	Note 5	
12mm	Single (4mm) & Double (8mm)	8.2 (0.323)	10.25 (0.404)	5.5 ± 0.05 (0.217 ± 0.002)	8.0 ± 0.10 (0.315 ± 0.004)	4.6 (0.181)	12.3 (0.484)		
16mm	Triple (12mm)	12.1 (0.476)	14.25 (0.561)	5.5 ± 0.05 (0.217 ± 0.002)	8.0 ± 0.10 (0.315 ± 0.004)	4.6 (0.181)	16.3 (0.642)		

1. The embossment hole location shall be measured from the sprocket hole controlling the location of the embossment. Dimensions of embossment location and hole location shall be applied independent of each other.
2. The tape with or without components shall pass around R without damage (see Figure 5).
3. If S₁ < 1.0 mm, there may not be enough area for cover tape to be properly applied (see EIA Document 481 paragraph 4.3 (b)).
4. B₁ dimension is a reference dimension for tape feeder clearance only.
5. The cavity defined by A₀, B₀ and K₀ shall surround the component with sufficient clearance that:
 - (a) the component does not protrude above the top surface of the carrier tape.
 - (b) the component can be removed from the cavity in a vertical direction without mechanical restriction, after the top cover tape has been removed.
 - (c) rotation of the component is limited to 20° maximum for 8 and 12mm tapes and 10° maximum for 16mm tapes (see Figure 3).
 - (d) lateral movement of the component is restricted to 0.5 mm maximum for 8mm and 12mm wide tape and to 1.0mm maximum for 16mm tape (see Figure 4).
 - (e) see Addendum in EIA Document 481 for standards relating to more precise taping requirements.

Packaging Information Performance Notes

1. **Cover Tape Break Force:** 1.0 Kg minimum.
2. **Cover Tape Peel Strength:** The total peel strength of the cover tape from the carrier tape shall be:

Tape Width	Peel Strength
8mm	0.1 Newton to 1.0 Newton (10gf to 100gf)
12mm & 16mm	0.1 Newton to 1.3 Newton (10gf to 130gf)

The direction of the pull shall be opposite the direction of the carrier tape travel. The pull angle of the carrier tape shall be 165° to 180° from the plane of the carrier tape. During peeling, the carrier and/or cover tape shall be pulled at a velocity of 300±10 mm/minute.

3. **Labeling:** Bar code labeling (standard or custom) shall be on the side of the reel opposite the sprocket holes. Refer to EIA-556 and EIA-624.

Figure 2 – Maximum Component Rotation

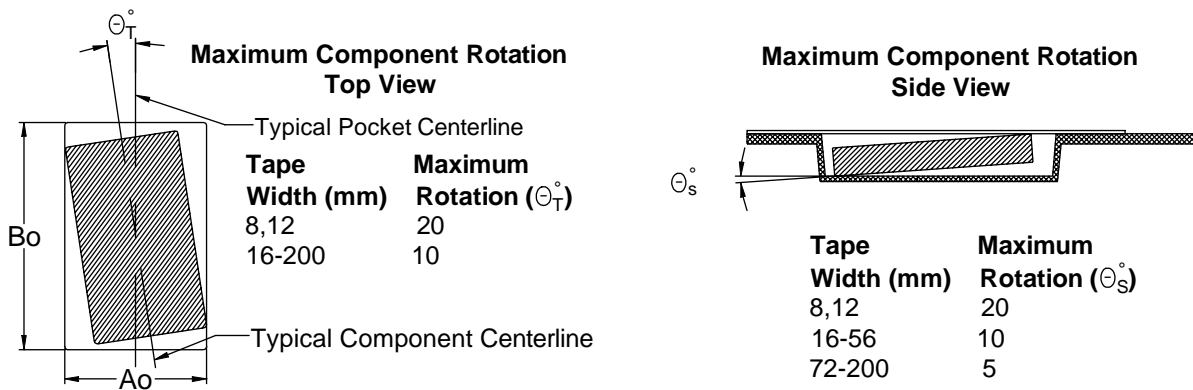

Figure 3 – Maximum Lateral Movement

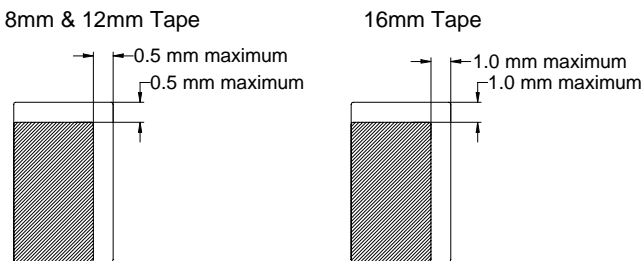

Figure 4 – Bending Radius

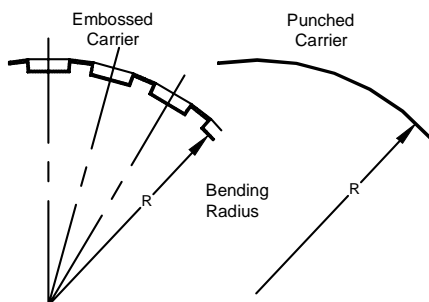

Figure 5 – Reel Dimensions

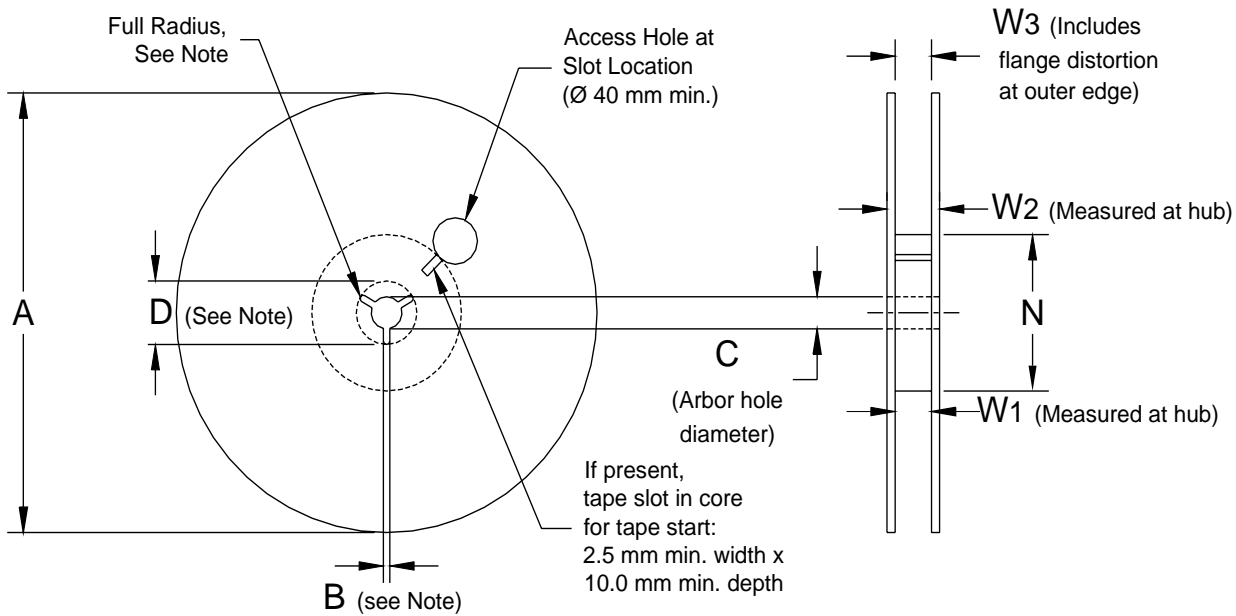

Table 5 – Reel Dimensions

Metric will govern

Constant Dimensions — Millimeters (Inches)				
Tape Size	A	B Min	C	D Min
8mm	178 ± 0.20 (7.008 ± 0.008)	1.5 (0.059)	13.0 +0.5/-0.2 (0.521 +0.02/-0.008)	20.2 (0.795)
12mm	or			
16mm	330 ± 0.20 (13.000 ± 0.008)			
Variable Dimensions — Millimeters (Inches)				
Tape Size	N Min	W ₁	W ₂ Max	W ₃
8mm	50 (1.969)	8.4 +1.5/-0.0 (0.331 +0.059/-0.0)	14.4 (0.567)	Shall accommodate tape width without interference
12mm		12.4 +2.0/-0.0 (0.488 +0.078/-0.0)	18.4 (0.724)	
16mm		16.4 +2.0/-0.0 (0.646 +0.078/-0.0)	22.4 (0.882)	

Figure 6 – Tape Leader & Trailer Dimensions

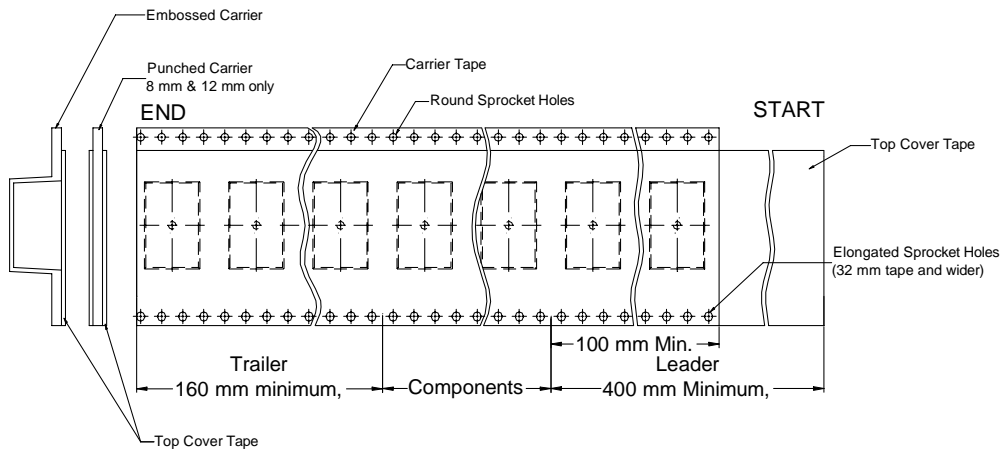
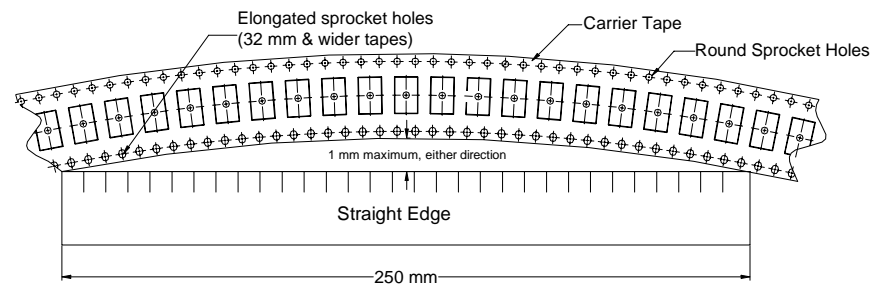

Figure 7 – Maximum Camber



KEMET Corporation World Headquarters

2835 KEMET Way
Simpsonville, SC 29681

Mailing Address:
P.O. Box 5928
Greenville, SC 29606

www.kemet.com
Tel: 864-963-6300
Fax: 864-963-6521

Corporate Offices

Fort Lauderdale, FL
Tel: 954-766-2800

North America

Southeast

Lake Mary, FL
Tel: 407-855-8886

Northeast

Wilmington, MA
Tel: 978-658-1663

West Chester, PA
Tel: 610-692-4642

Central

Schaumburg, IL
Tel: 847-882-3590

Carmel, IN
Tel: 317-706-6742

West

Milpitas, CA
Tel: 408-433-9950

Mexico

Zapopan, Jalisco
Tel: 52-33-3123-2141

Europe

Southern Europe

Geneva, Switzerland
Tel: 41-22-715-0100

Paris, France
Tel: 33-1-4646-1009

Sasso Marconi, Italy
Tel: 39-051-939111

Milan, Italy
Tel: 39-02-57518176

Rome, Italy
Tel: 39-06-23231718

Madrid, Spain
Tel: 34-91-804-4303

Central Europe

Landsberg, Germany
Tel: 49-8191-3350800

Dortmund, Germany
Tel: 49-2307-3619672

Kwidzyn, Poland
Tel: 48-55-279-7025

Northern Europe

Bishop's Stortford, United Kingdom
Tel: 44-1279-757201

Weymouth, United Kingdom
Tel: 44-1305-830747

Coatbridge, Scotland
Tel: 44-1236-434455

Färjestaden, Sweden
Tel: 46-485-563934

Espoo, Finland
Tel: 358-9-5406-5000

Asia

Northeast Asia

Hong Kong
Tel: 852-2305-1168

Shenzhen, China
Tel: 86-755-2518-1306

Beijing, China
Tel: 86-10-5829-1711

Shanghai, China
Tel: 86-21-6447-0707

Taipei, Taiwan
Tel: 886-2-27528585

Southeast Asia

Singapore
Tel: 65-6586-1900

Penang, Malaysia
Tel: 60-4-6430200

Bangalore, India
Tel: 91-806-53-76817

Note: KEMET reserves the right to modify minor details of internal and external construction at any time in the interest of product improvement. KEMET does not assume any responsibility for infringement that might result from the use of KEMET Capacitors in potential circuit designs. KEMET is a registered trademark of KEMET Electronics Corporation.

Other KEMET Resources

Tools	
Resource	Location
Configure A Part: CapEdge	http://capacitoredge.kemet.com
SPICE & FIT Software	http://www.kemet.com/spice
Search Our FAQs: KnowledgeEdge	http://www.kemet.com/keask

Product Information	
Resource	Location
Products	http://www.kemet.com/products
Technical Resources (Including Soldering Techniques)	http://www.kemet.com/technicalpapers
RoHS Statement	http://www.kemet.com/rohs
Quality Documents	http://www.kemet.com/qualitydocuments

Product Request	
Resource	Location
Sample Request	http://www.kemet.com/sample
Engineering Kit Request	http://www.kemet.com/kits

Contact	
Resource	Location
Website	www.kemet.com
Contact Us	http://www.kemet.com/contact
Investor Relations	http://www.kemet.com/ir
Call Us	1-877-MyKEMET
Twitter	http://twitter.com/kemetcapacitors

Disclaimer

All product specifications, statements, information and data (collectively, the "Information") are subject to change without notice.

All Information given herein is believed to be accurate and reliable, but is presented without guarantee, warranty, or responsibility of any kind, expressed or implied.

Statements of suitability for certain applications are based on our knowledge of typical operating conditions for such applications, but are not intended to constitute – and we specifically disclaim – any warranty concerning suitability for a specific customer application or use. This Information is intended for use only by customers who have the requisite experience and capability to determine the correct products for their application. Any technical advice inferred from this Information or otherwise provided by us with reference to the use of our products is given gratis, and we assume no obligation or liability for the advice given or results obtained.

Although we design and manufacture our products to the most stringent quality and safety standards, given the current state of the art, isolated component failures may still occur. Accordingly, customer applications which require a high degree of reliability or safety should employ suitable designs or other safeguards (such as installation of protective circuitry or redundancies) in order to ensure that the failure of an electrical component does not result in a risk of personal injury or property damage.

Although all product-related warnings, cautions and notes must be observed, the customer should not assume that all safety measures are indicated or that other measures may not be required.

