

## Overview

Multilayer metallized paper, encapsulated and impregnated in self-extinguishing material meeting the requirements of UL 94 V-0.

## Applications

For worldwide use in electromagnetic interference suppression in all X2 and across-the-line applications. Also for use in high AC and DC voltage applications such as commutator capacitor in converters and ignition circuits.

## Benefits

- Approvals: ENEC, UL
- Rated voltage: 660 VAC 50/60 Hz
- Capacitance range: 0.001 – 0.1  $\mu$ F
- Lead spacing: 15.2 – 25.4 mm
- Capacitance tolerance:  $\pm$ 20%,  $\pm$ 10%,  $\pm$ 5% on request
- Climatic category 40/85/56, IEC 60068-1
- Tape and reel in accordance with IEC 60286-2
- RoHS Compliant and lead-free terminations
- Operating temperature range of -40°C to +85°C
- 100% screening factory test at 3,000 VDC
- The highest possible safety regarding active and passive flammability
- Excellent self-healing properties ensure long life even when subjected to frequent overvoltages
- Good resistance to ionization due to impregnated dielectric
- High dV/dt capability
- The impregnated paper ensures excellent stability and outstanding reliability properties, especially in applications with continuous operation

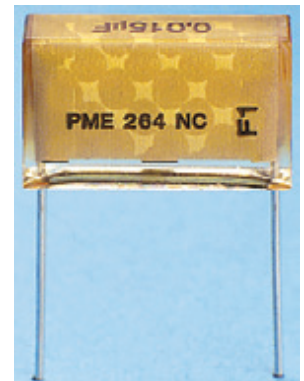

## Legacy Part Number System

PME264	N	B	5100	M	R30
Series	Rated Voltage (VAC)	Lead Spacing (mm)	Capacitance Code (pF)	Capacitance Tolerance	Lead and Packaging Code
X2, Metallized Paper	N = 660	B = 15.2 C = 20.3 E = 25.4	Digits 2-4(3) indicates the first three digits of the capacitance value. First digit indicates the total number of digits in the capacitance value.	J = $\pm$ 5% K = $\pm$ 10% M = $\pm$ 20%	See Ordering Options Table

## New KEMET Part Number System

P	264	Q	E	103	M	660	A
Capacitor Class	Series	Lead Spacing (mm)	Size Code	Capacitance Code (EIA pF)	Capacitance Tolerance	Rated Voltage (VAC)	Lead and Packaging Code
P = Paper	X2, Metallized Paper	Q = 15.2 C = 20.3 E = 25.4	See Dimension Table	First two digits indicate the two most significant digits of the capacitance value in picofarads. The third digit is the number of following zeroes.	J = $\pm$ 5% K = $\pm$ 10% M = $\pm$ 20%	660 = 660	See Ordering Options Table

## Ordering Options Table

Lead Spacing Nominal (mm)	Type of Leads and Packaging	Lead Length (mm)	KEMET Lead and Packaging Code	Legacy Lead and Packaging Code
15.2	<b>Standard Lead and Packaging Options</b>			
	Bulk (Bag)–Short Leads	6 +0/-1	C	R06
	Bulk (Bag)–Max Length Leads	30 +5/-0	A	R30
	Tape & Reel (Standard Reel)	$H_0 = 18.5 \pm 0.5$	L	R19T0
	<b>Other Lead and Packaging Options</b>			
	Tape & Reel (Standard Reel)	$H_0 = 18.5 \pm 0.5$	P	R19T1
20.3	<b>Standard Lead and Packaging Options</b>			
	Bulk (Tray)–Short Leads	6 +0/-1	C	R06
	Bulk (Bag)–Max Length Leads	30 +5/-0	A	R30
	Tape & Reel (Standard Reel)	$H_0 = 18.5 \pm 0.5$	L	R19T0
	<b>Other Lead and Packaging Options</b>			
	Tape & Reel (Large Reel)	$H_0 = 18.5 \pm 0.5$	P	R19T1
25.4	<b>Standard Lead and Packaging Options</b>			
	Bulk (Tray)–Short Leads	6 +0/-1	C	R06
	Bulk (Bag)–Max Length Leads	30 +5/-0	A	R30

## Dimensions – Millimeters

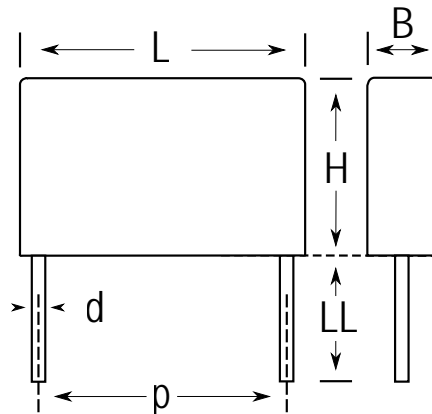

Size Code	p		B		H		L		d	
	Nominal	Tolerance	Nominal	Tolerance	Nominal	Tolerance	Nominal	Tolerance	Nominal	Tolerance
QE	15.2	+/-0.4	5.2	Max	10.5	Max	18.5	Max	0.8	+/-0.05
QM	15.2	+/-0.4	7.3	Max	13	Max	18.5	Max	0.8	+/-0.05
CE	20.3	+/-0.4	7.6	Max	14	Max	24	Max	0.8	+/-0.05
CJ	20.3	+/-0.4	9	Max	15	Max	24	Max	0.8	+/-0.05
CP	20.3	+/-0.4	11.3	Max	16.5	Max	24	Max	0.8	+/-0.05
EG	25.4	+/-0.4	10.5	Max	17.3	Max	30.5	Max	1	+/-0.05
EJ	25.4	+/-0.4	12.1	Max	19	Max	30.5	Max	1	+/-0.05
EL	25.4	+/-0.4	15.3	Max	22	Max	30.5	Max	1	+/-0.05

**Note: See Ordering Options Table for lead length (LL) options.**



## Performance Characteristics

Rated Voltage	660 VAC 50/60 Hz
Capacitance Range	0.001 – 0.1 $\mu$ F
Capacitance Tolerance	$\pm$ 20%, $\pm$ 10%, $\pm$ 5% on request
Temperature Range	-40°C to +85°C
Climatic Category	40/85/56
Approvals	ENEC, UL
Dissipation Factor	Maximum Values at +23°C
	1 kHz   1.3%
Test Voltage Between Terminals	The 100% screening factory test is carried out at 3,000 VDC. The voltage level is selected to meet the requirements in applicable equipment standards. All electrical characteristics are checked after the test. It is not permitted to repeat this test as there is a risk to damage the capacitor. KEMET is not liable in such case for any failures.
Insulation Resistance	Between Terminals:
	$\geq$ 12,000 M $\Omega$
In DC Applications	Recommended voltage $\leq$ 1,500 VDC

## Environmental Test Data

Test	IEC Publication	Procedure
Endurance	EN/IEC 60384-14	1.25 x $V_R$ VAC 50 Hz, once every hour increase to 1,000 VAC for 0.1 second, 1,000 hours at upper rated temperature
Vibration	IEC 60068-2-6 Test Fc	3 directions at 2 hours each 10 – 55 Hz at 0.75 mm or 98 m/s <sup>2</sup>
Bump	IEC 60068-2-29 Test Eb	1,000 bumps at 390 m/s <sup>2</sup>
Change of Temperature	IEC 60068-2-14 Test Na	Upper and lower rated temperature 5 cycles
Active Flammability	IEC 60384-14	$V_R$ + 20 surge pulses at 2.5 kV (pulse every 5 seconds)
Passive Flammability	IEC 60384-14	IEC 60384-1, IEC 60695-11-5 Needle-flame test
Damp Heat Steady State	IEC 60068-2-78 Test Cab	+40°C and 93% RH, 56 days

## Approvals

Mark	Specification	File Number
	EN/IEC 60384-14	SE/0140-25A
	UL 1283 ( $V_R$ = 600 VAC)	E100117

## Environmental Compliance

All KEMET EMI capacitors are RoHS Compliant and Halogen Free.



**Table 1 – Ratings & Part Number Reference**

Cap Value ( $\mu\text{F}$ )	Max Dimensions in mm			Lead Spacing (p)	dV/dt (V/ $\mu\text{s}$ )	New KEMET Part Number	Legacy Part Number
	B	H	L				
0.001	5.2	10.5	18.5	15.2	2000	P264QE102(1)660(2)	PME264NB4100(1)(2)
0.0015	5.2	10.5	18.5	15.2	2000	P264QE152(1)660(2)	PME264NB4150(1)(2)
0.0022	5.2	10.5	18.5	15.2	2000	P264QE222(1)660(2)	PME264NB4220(1)(2)
0.0033	5.2	10.5	18.5	15.2	2000	P264QE332(1)660(2)	PME264NB4330(1)(2)
0.0047	5.2	10.5	18.5	15.2	2000	P264QE472(1)660(2)	PME264NB4470(1)(2)
0.0068	7.3	13	18.5	15.2	1400	P264QM682(1)660(2)	PME264NB4680(1)(2)
0.010	7.3	13	18.5	15.2	1400	P264QM103(1)660(2)	PME264NB5100(1)(2)
0.015	7.6	14	24	20.3	1400	P264CE153(1)660(2)	PME264NC5150(1)(2)
0.022	9	15	24	20.3	1400	P264CJ223(1)660(2)	PME264NC5220(1)(2)
0.033	11.3	16.5	24	20.3	1000	P264CP333(1)660(2)	PME264NC5330(1)(2)
0.047	10.5	17.3	30.5	25.4	1000	P264EG473(1)660(2)	PME264NE5470(1)(2)
0.068	12.1	19	30.5	25.4	1000	P264EJ683(1)660(2)	PME264NE5680(1)(2)
0.1	15.3	22	30.5	25.4	600	P264EL104(1)660(2)	PME264NE6100(1)(2)
Cap Value ( $\mu\text{F}$ )	B (mm)	H (mm)	L (mm)	Lead Spacing (p)	dV/dt (V/ $\mu\text{s}$ )	New KEMET Part Number	Legacy Part Number

(1)  $M = \pm 20\%$ ,  $K = \pm 10\%$ ,  $J = \pm 5\%$  on request.

(2) Insert ordering code for lead type and packaging. See table for available options.

## Soldering Process

The implementation of the RoHS Directive has required the use of SnAuCu (SAC) or SnCu alloys as primary solder. These alloys require a higher liquidus temperature (217°C – 221°C) as compared to SnPb eutectic alloy (183°C). Due to the higher pre-heat and wave temperatures, the heat stress to components has increased considerably. Polypropylene capacitors are especially sensitive to soldering temperature due to the relatively low melting point of polypropylene material (160°C – 170°C). As a result, wave soldering can be destructive, especially to mechanically small polypropylene capacitors with lead spacings of 5 – 10 mm. For more information, please refer to KEMET's Recommended Soldering Profiles or contact a KEMET representative. IEC Publication 61760–1 Edition 2 may also be consulted for general guidelines.

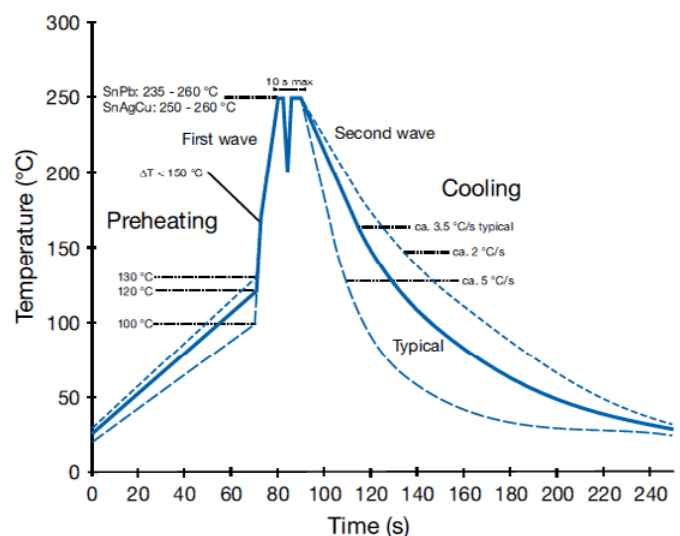

## Marking

- KEMET's logo
- Series
- Capacitance
- Capacitance tolerance
- Rated voltage
- Capacitor class
- Approval marks
- Manufacturing date code
- IEC climatic category
- Passive flammability class
- Manufacturing plant

## Packaging Quantities

Lead Spacing (mm)	Thickness (mm)	Height (mm)	Length (mm)	Bulk Short Leads	Bulk Long Leads	Standard Reel ∅ 360 mm	Large Reel ∅ 500 mm	Ammo Formed
15.2	5.5	12.5	18	1000	500	600		
	6.5	12.5	18	600	400	400		
	7.5	14.5	18	600	400	400		
	8.5	16	18	400	250	400		
	5.2	10.5	18.5	1000	500	600		
	5.5	11	18.5	1000	500	500		
	6	12.5	18.5	600	400	400		
	7.3	13	18.5	600	400	400	800	
	7.8	13.5	18.5	600	400	400		
8.5	14.3	18.5	500	300	350			
20.3	7.6	14	24	1500	250	250	500	
	8.4	14	24	1200	200	250	500	
	9	15	24	1500	200	250		
	11.3	16.5	24	1000	150	180	400	
25.4	10.6	16.1	30.5	1000	150			
	10.5	17.3	30.5	1000	100			
	12.1	19	30.5	800	100			
	15.3	22	30.5	600	75			

## Lead Taping & Packaging (IEC 60286–2)

Lead Spacing 10.2 – 15.2 mm

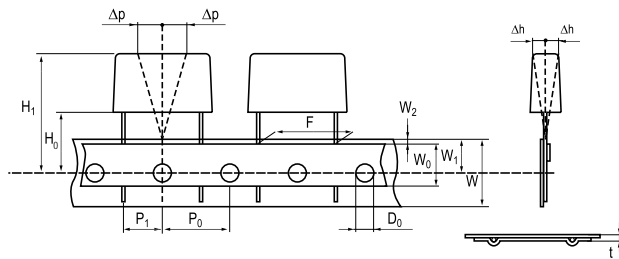

Lead Spacing 20.3 – 22.5 mm

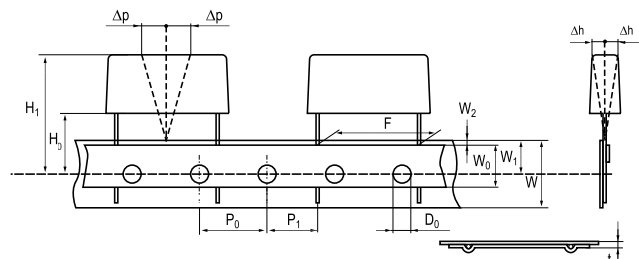

Formed Leads from 10.2 to 7.5 mm

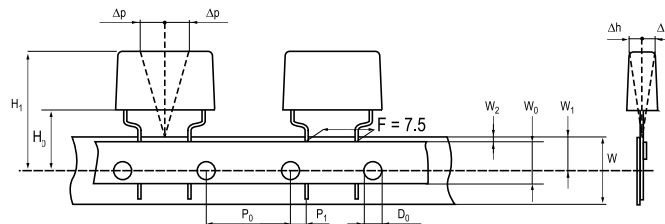

## Taping Specification

Dimensions in mm								Standard IEC 60286–2
Lead spacing	+6/-0.1	F	Formed 7.5	10.2	15.2	20.3	22.5	F
Carrier tape width	+/-0.5	W	18	18	18	18	18	18 <sup>+1/-0.5</sup>
Hold-down tape width	+/-0.3	W <sub>0</sub>	9	12	12	12	12	
Position of sprocket hole	+/-0.5	W <sub>1</sub>	9	9	9	9	9	9 <sup>+0.75/-0.5</sup>
Distance between tapes	MAX	W <sub>2</sub>	3	3	3	3	3	3
Sprocket hole diameter	+/-0.2	D <sub>0</sub>	4	4	4	4	4	4
Feed hole lead spacing	+/-0.3	P <sub>0</sub> <sup>(1)</sup>	12.7 <sup>(4)</sup>	12.7	12.7	12.7	12.7	12.7
Distance lead - feed hole	+/-0.7	P <sub>1</sub>	3.75	7.6	5.1	8.9	5.3	P <sup>1</sup>
Deviation tape - plane	MAX	Δp	1.3	1.3	1.3	1.3	1.3	1.3
Lateral deviation	MAX	Δh	2	2	2	2	2	2
Total thickness	+/-0.2	t	0.7	0.7	0.7	0.7	0.9 <sup>MAX</sup>	0.9 <sup>MAX</sup>
Sprocket hole/cap body	NOM	H <sub>0</sub> <sup>(2)</sup>	18 <sup>+2/-0</sup>	18 <sup>+2/-0</sup>	18 <sup>+2/-0</sup>	18 <sup>+2/-0</sup>	18.5 <sup>+/-0.5</sup>	18 <sup>+2/-0</sup>
Sprocket hole/top of cap body	MAX	H <sub>1</sub> <sup>(3)</sup>	35	35	35	35	58	58 <sup>MAX</sup>

(1) Maximum cumulative feed hole error, 1 mm per 20 parts.

(2) 16.5 mm available on request.

(3) Depending on case size.

(4) 15 mm available on request.

## Lead Taping & Packaging (IEC 60286–2) cont'd

### Ammo Specifications

Series	Dimensions (mm)		
	H	W	T
R4x, R4x+R, R7x, RSB	360	340	59
F5A, F5B, F5D			
F6xx, F8xx			
PHExxx, PMExxx, PMRxxx	330	330	50

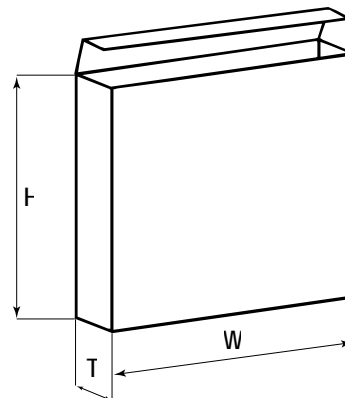

### Reel Specifications

Series	Dimensions (mm)		
	D	H	W
R4x, R4x+R, R7x, RSB	355 500	30	55 (Max)
F5A, F5B, F5D		25	
F6xx, F8xx			
PHExxx, PMExxx, PMRxxx	360 500	30	46 (Max)

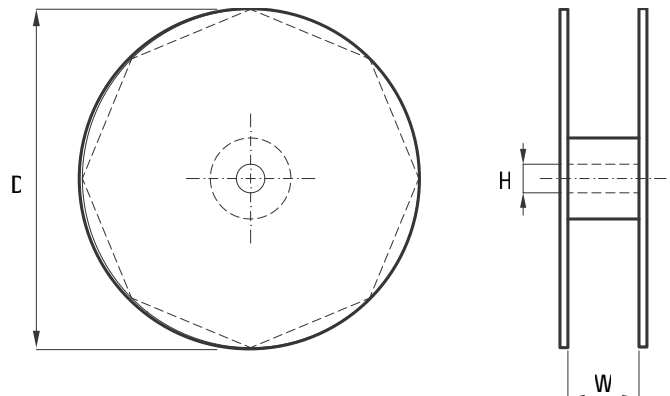

### Manufacturing Date Code (IEC–60062)

Y = Year, Z = Month			
Year	Code	Month	Code
2000	M	January	1
2001	N	February	2
2002	P	March	3
2003	R	April	4
2004	S	May	5
2005	T	June	6
2006	U	July	7
2007	V	August	8
2008	W	September	9
2009	X	October	O
2010	A	November	N
2011	B	December	D
2012	C		
2013	D		
2014	E		
2015	F		
2016	H		
2017	J		
2018	K		
2019	L		
2020	M		

## KEMET Corporation World Headquarters

2835 KEMET Way  
Simpsonville, SC 29681

Mailing Address:  
P.O. Box 5928  
Greenville, SC 29606

www.kemet.com  
Tel: 864-963-6300  
Fax: 864-963-6521

### Corporate Offices

Fort Lauderdale, FL  
Tel: 954-766-2800

## North America

### Southeast

Lake Mary, FL  
Tel: 407-855-8886

### Northeast

Wilmington, MA  
Tel: 978-658-1663

West Chester, PA  
Tel: 610-692-4642

### Central

Novi, MI  
Tel: 248-994-1030

Carmel, IN  
Tel: 317-706-6742

### West

Milpitas, CA  
Tel: 408-433-9950

### Mexico

Zapopan, Jalisco  
Tel: 52-33-3123-2141

## Europe

### Southern Europe

Geneva, Switzerland  
Tel: 41-22-715-0100

Paris, France  
Tel: 33-1-4646-1009

Sasso Marconi, Italy  
Tel: 39-051-939111

Milan, Italy  
Tel: 39-02-57518176

Rome, Italy  
Tel: 39-06-23231718

Madrid, Spain  
Tel: 34-91-804-4303

### Central Europe

Landsberg, Germany  
Tel: 49-8191-3350800

Dortmund, Germany  
Tel: 49-2307-3619672

Kwidzyn, Poland  
Tel: 48-55-279-7025

### Northern Europe

Bishop's Stortford, United Kingdom  
Tel: 44-1279-757201

Weymouth, United Kingdom  
Tel: 44-1305-830747

Coatbridge, Scotland  
Tel: 44-1236-434455

Färjestaden, Sweden  
Tel: 46-485-563934

Espoo, Finland  
Tel: 358-9-5406-5000

## Asia

### Northeast Asia

Hong Kong  
Tel: 852-2305-1168

Shenzhen, China  
Tel: 86-755-2518-1306

Beijing, China  
Tel: 86-10-5829-1711

Shanghai, China  
Tel: 86-21-6447-0707

Taipei, Taiwan  
Tel: 886-2-27528585

### Southeast Asia

Singapore  
Tel: 65-6586-1900

Penang, Malaysia  
Tel: 60-4-6430200

Bangalore, India  
Tel: 91-806-53-76817

*Note: KEMET reserves the right to modify minor details of internal and external construction at any time in the interest of product improvement. KEMET does not assume any responsibility for infringement that might result from the use of KEMET Capacitors in potential circuit designs. KEMET is a registered trademark of KEMET Electronics Corporation.*

## Other KEMET Resources

Tools	
Resource	Location
Configure A Part: CapEdge	<a href="http://capacitoredge.kemet.com">http://capacitoredge.kemet.com</a>
SPICE & FIT Software	<a href="http://www.kemet.com/spice">http://www.kemet.com/spice</a>
Search Our FAQs: KnowledgeEdge	<a href="http://www.kemet.com/keask">http://www.kemet.com/keask</a>

Product Information	
Resource	Location
Products	<a href="http://www.kemet.com/products">http://www.kemet.com/products</a>
Technical Resources (Including Soldering Techniques)	<a href="http://www.kemet.com/technicalpapers">http://www.kemet.com/technicalpapers</a>
RoHS Statement	<a href="http://www.kemet.com/rohs">http://www.kemet.com/rohs</a>
Quality Documents	<a href="http://www.kemet.com/qualitydocuments">http://www.kemet.com/qualitydocuments</a>

Product Request	
Resource	Location
Sample Request	<a href="http://www.kemet.com/sample">http://www.kemet.com/sample</a>
Engineering Kit Request	<a href="http://www.kemet.com/kits">http://www.kemet.com/kits</a>

Contact	
Resource	Location
Website	<a href="http://www.kemet.com">www.kemet.com</a>
Contact Us	<a href="http://www.kemet.com/contact">http://www.kemet.com/contact</a>
Investor Relations	<a href="http://www.kemet.com/ir">http://www.kemet.com/ir</a>
Call Us	1-877-MyKEMET
Twitter	<a href="http://twitter.com/kemetcapacitors">http://twitter.com/kemetcapacitors</a>

## Disclaimer

All product specifications, statements, information and data (collectively, the "Information") are subject to change without notice.

All Information given herein is believed to be accurate and reliable, but is presented without guarantee, warranty, or responsibility of any kind, expressed or implied.

Statements of suitability for certain applications are based on our knowledge of typical operating conditions for such applications, but are not intended to constitute – and we specifically disclaim – any warranty concerning suitability for a specific customer application or use. This Information is intended for use only by customers who have the requisite experience and capability to determine the correct products for their application. Any technical advice inferred from this Information or otherwise provided by us with reference to the use of our products is given gratis, and we assume no obligation or liability for the advice given or results obtained.

Although we design and manufacture our products to the most stringent quality and safety standards, given the current state of the art, isolated component failures may still occur. Accordingly, customer applications which require a high degree of reliability or safety should employ suitable designs or other safeguards (such as installation of protective circuitry or redundancies) in order to ensure that the failure of an electrical component does not result in a risk of personal injury or property damage.

Although all product-related warnings, cautions and notes must be observed, the customer should not assume that all safety measures are indicated or that other measures may not be required.

Class X2

Metallized Impregnated Paper EMI Suppression Capacitors – PME264 Series, Class X2, 660 VAC

---