

SW600

Automatic Winding Machine for Film/Foil Power Capacitors



MAIN FEATURES

- Winding of 6 films and 2 aluminum foils.
- Film pick-up by collapsible winding arbor.
- Aluminum foil edge folding; foil start and end folding
- Automatic extraction of wound element from winding arbor.
- Wound element pre-flattening.
- Pre-flattening element unloading onto conveyor belt.

PRODUCT

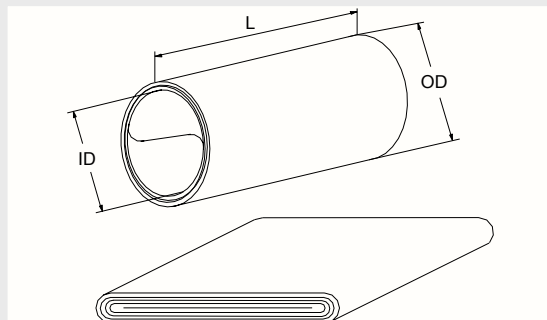

GENERAL INFORMATION

L	270	to	530	mm
ID	60	to	127	mm
OD	150 mm max.			