

R49+R Series Metallized Polypropylene Film, Class X1, 330 VAC with Internal Discharge Resistor

Overview

Metallized polypropylene film encapsulated with self-extinguishing resin in a box of material recognized to UL 94 V-0.

Applications

For worldwide use as an electromagnetic interference suppressor in all X1 and across-the-line applications.

Benefits

- Approvals: ENEC, UL, cUL
- Rated voltage: 330 VAC 50/60 Hz
- Capacitance range: 0.33 – 6.8 μ F
- Lead spacing: 27.5 – 37.5 mm
- Capacitance tolerance: \pm 20%, \pm 10%, \pm 5% on request
- Climatic category: 40/110/56, IEC 60068-1
- Tape and reel packaging in accordance with IEC 60286-2
- RoHS Compliant and lead-free terminations
- Operating temperature range of -40°C to +110°C
- 100% screening factory test at 2,200 VDC/1,500 VAC



Part Number System

R49	A	R	3330	00	B1	M	E
Series	Rated Voltage (VAC)	Lead Spacing (mm)	Capacitance Code (pF)	Lead and Packaging Code	Internal Use	Capacitance Tolerance	Value of Discharge Resistor
X1, Metallized Polypropylene	A = 330	R = 27.5 W = 37.5	Digits 2-4 indicate the first three digits of the capacitance value. First digit indicates the number of zeros to be added.	See Ordering Options Table	A1, B1, B2(Standard)	J = \pm 5% K = \pm 10% M = \pm 20%	470 k Ω = E 680 k Ω = F 1 M Ω = G 1.2 M Ω = L 1.5 M Ω = N 2.2 M Ω = P 3.3 M Ω = Q 4.7 M Ω = S 6.8 M Ω = T 10 M Ω = V

Ordering Options Table

Lead Spacing Nominal (mm)	Type of Leads and Packaging	Lead Length (mm)	Lead and Packaging Code
27.5	Standard Lead and Packaging Options		
	Bulk (Tray)– Short Leads	4 +2/-0	00
	Tape & Reel (Large Reel)	H ₀ = 18.5 +/-0.5	CK
	Other Lead and Packaging Options		
	Bulk (Tray)– Long Leads	25 +2/-1	50
	Bulk (Tray)– Max Length Leads	30 +5/-0	40
37.5	Standard Lead and Packaging Options		
	Bulk (Tray)– Short Leads	4 +2/-0	00
	Other Lead and Packaging Options		
	Bulk (Tray)– Long Leads	25 +2/-1	50
	Bulk (Tray)– Max Length Leads	30 +5/-0	40

Dimensions – Millimeters

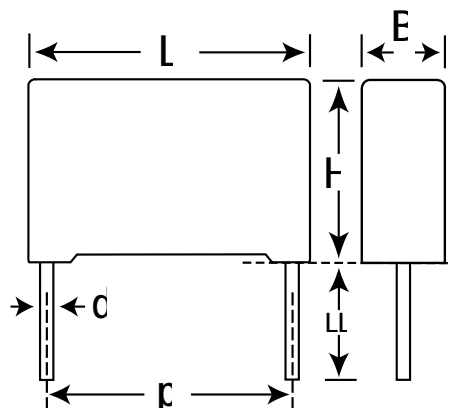

p		B		H		L		d	
Nominal	Tolerance	Nominal	Tolerance	Nominal	Tolerance	Nominal	Tolerance	Nominal	Tolerance
27.5	+/-0.4	11.0	+0.2/-0	20.0	+0.1/-0	32.0	+0.3/-0	0.8	+/-0.05
27.5	+/-0.4	13.0	+0.2/-0	22.0	+0.1/-0	32.0	+0.3/-0	0.8	+/-0.05
27.5	+/-0.4	14.0	+0.2/-0	28.0	+0.1/-0	32.0	+0.3/-0	0.8	+/-0.05
27.5	+/-0.4	18.0	+0.2/-0	33.0	+0.1/-0	32.0	+0.3/-0	0.8	+/-0.05
27.5	+/-0.4	22.0	+0.2/-0	37.0	+0.1/-0	32.0	+0.3/-0	0.8	+/-0.05
27.5	+/-0.4	9.0	+0.2/-0	17.0	+0.1/-0	32.0	+0.3/-0	0.8	+/-0.05
37.5	+/-0.4	11.0	+0.3/-0	22.0	+0.1/-0	41.5	+0.3/-0	1	+/-0.05
37.5	+/-0.4	13.0	+0.3/-0	24.0	+0.1/-0	41.5	+0.3/-0	1	+/-0.05
37.5	+/-0.4	16.0	+0.3/-0	28.5	+0.1/-0	41.5	+0.3/-0	1	+/-0.05
37.5	+/-0.4	19.0	+0.3/-0	32.0	+0.1/-0	41.5	+0.3/-0	1	+/-0.05
37.5	+/-0.4	20.0	+0.3/-0	40.0	+0.1/-0	41.5	+0.3/-0	1	+/-0.05
37.5	+/-0.4	24.0	+0.3/-0	44.0	+0.1/-0	41.5	+0.3/-0	1	+/-0.05

Note: See Ordering Options Table for lead length (LL) options.

Performance Characteristics

Rated Voltage	330 VAC 50/60 Hz	
Capacitance Range	0.33 – 6.8 μF	
Capacitance Tolerance	$\pm 20\%$, $\pm 10\%$, $\pm 5\%$ on request	
Temperature Range	-40°C to +110°C	
Climatic Category	40/110/56	
Approvals	ENEC, UL, cUL	
Dissipation Factor	Maximum Values at +23°C	
	1 kHz	0.1%
Test Voltage Between Terminals	The 100% screening factory test is carried out at 2,200 VDC/1,500 VAC. The voltage level is selected to meet the requirements in applicable equipment standards. All electrical characteristics are checked after the test. It is not permitted to repeat this test as there is a risk to damage the capacitor. KEMET is not liable in such case for any failures.	
Insulation Resistance	Between Terminals:	
	$C \leq 0.33 \mu\text{F}$	$\geq 100,000 \text{ M}\Omega$
	$C > 0.33 \mu\text{F}$	$\geq 30,000 \text{ M}\Omega \cdot \mu\text{F}$
In DC Applications	Recommended voltage $\leq 800 \text{ VDC}$	

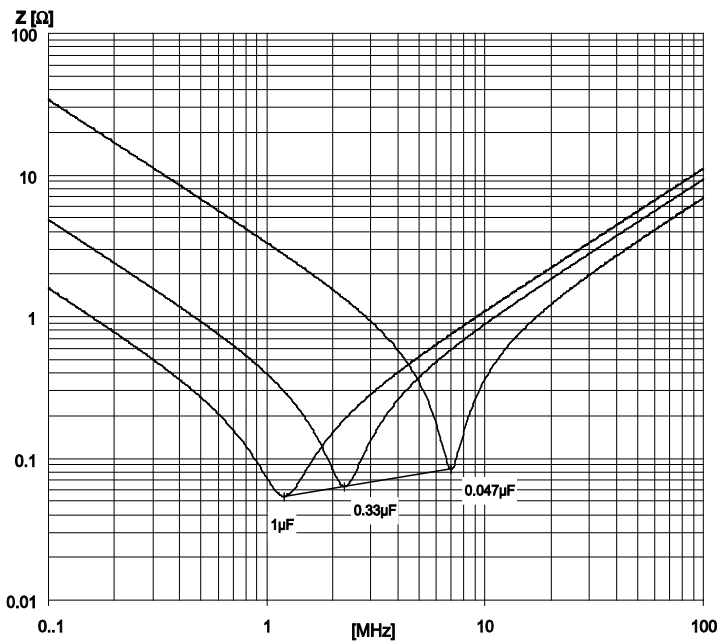

Impedance Graph



Environmental Test Data

Test	IEC Publication	Procedure
Endurance	IEC 60384-14	$1.25 \times V_R$ VAC 50 Hz, once every hour increase to 1,000 VAC for 0.1 second, 1,000 hours at upper rated temperature
Vibration	IEC 60068-2-6 Test Fc	3 directions at 2 hours each 10 – 55 Hz at 0.75 mm or 98 m/s ²
Bump	IEC 60068-2-29 Test Eb	1,000 bumps at 390 m/s ²
Change of Temperature	IEC 60068-2-14 Test Na	Upper and lower rated temperature 5 cycles
Active Flammability	IEC 60384-14	$V_R + 20$ surge pulses at 2.5 kV (pulse every 5 seconds)
Passive Flammability	IEC 60384-14	IEC 60384-1, IEC 60695-11-5 Needle-flame test
Damp Heat Steady State	IEC 60068-2-78 Test Cab	+40°C and 93% RH, 56 days

Approvals

Mark	Specification	File Number
	EN/IEC 60384-14	V4413
	UL 1283 (310 VAC)	E85238
	CSA-C22.2 No. 8 (310 VAC)	E85238

Environmental Compliance

All KEMET EMI capacitors are RoHS Compliant.



RoHS Compliant

Table 1 – Ratings & Part Number Reference

Cap Value (μF)	Dimensions in mm			Lead Spacing (p)	dV/dt (V/μs)	New Kemet Part Number	Legacy Part Number
	B	H	L				
0.33	9.0	17.0	32.0	27.5	200	49AR3330(1)B1(2)(3)	R49AR3330(1)B1(2)(3)
0.47	11.0	20.0	32.0	27.5	200	49AR3470(1)B1(2)(3)	R49AR3470(1)B1(2)(3)
0.68	13.0	22.0	32.0	27.5	200	49AR3680(1)B1(2)(3)	R49AR3680(1)B1(2)(3)
1.0	13.0	22.0	32.0	27.5	200	49AR4100(1)B1(4)(3)	R49AR4100(1)B1(4)(3)
1.0	14.0	28.0	32.0	27.5	200	49AR4100(1)B2(2)(3)	R49AR4100(1)B2(2)(3)
1.5	18.0	33.0	32.0	27.5	200	49AR4150(1)B1(4)(3)	R49AR4150(1)B1(4)(3)
1.5	14.0	28.0	32.0	27.5	200	49AR4150(1)B2(2)(3)	R49AR4150(1)B2(2)(3)
2.2	22.0	37.0	32.0	27.5	200	49AR4220(1)B1(2)(3)	R49AR4220(1)B1(2)(3)
0.68	11.0	22.0	41.5	37.5	100	49AW3680(1)A1(2)(3)	R49AW3680(1)A1(2)(3)
1.0	11.0	22.0	41.5	37.5	100	49AW4100(1)B1(2)(3)	R49AW4100(1)B1(2)(3)
1.5	13.0	24.0	41.5	37.5	100	49AW4150(1)B1(2)(3)	R49AW4150(1)B1(2)(3)
2.2	16.0	28.5	41.5	37.5	100	49AW4220(1)B1(2)(3)	R49AW4220(1)B1(2)(3)
3.3	19.0	32.0	41.5	37.5	100	49AW4330(1)B1(2)(3)	R49AW4330(1)B1(2)(3)
4.7	20.0	40.0	41.5	37.5	100	49AW4470(1)B1(2)(3)	R49AW4470(1)B1(2)(3)
6.8	30.0	45.0	41.5	37.5	100	49AW4680(1)B1(2)(3)	R49AW4680(1)B1(2)(3)
Cap Value (μF)	B (mm)	H (mm)	L (mm)	Lead Spacing (p)	dV/dt (V/μs)	New KEMET Part Number	Legacy Part Number

- (1) Insert lead and packaging code. See table for available options.
- (2) M = ±20%, K = ±10%, J = ±5% on request.
- (3) Insert code for Discharge resistor. See Part Number System.
- (4) M = ±20% (only available tolerance).

Soldering Process

The implementation of the RoHS Directive has required the use of SnAuCu (SAC) or SnCu alloys as primary solder. These alloys require a higher liquidus temperature (217°C – 221°C) as compared to SnPb eutectic alloy (183°C). Due to the higher pre-heat and wave temperatures, the heat stress to components has increased considerably. Polypropylene capacitors are especially sensitive to soldering temperature due to the relatively low melting point of polypropylene material (160°C – 170°C). As a result, wave soldering can be destructive, especially to mechanically small polypropylene capacitors with lead spacings of 5 – 10 mm. For more information, please refer to KEMET's Recommended Soldering Profiles or contact a KEMET representative. IEC Publication 61760–1 Edition 2 may also be consulted for general guidelines.

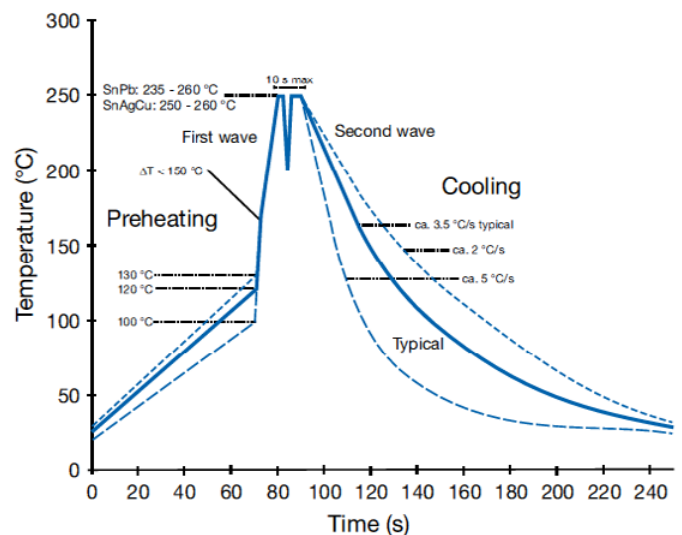

Marking

- KEMET's logo
- Series
- Capacitance
- Capacitance tolerance
- Rated voltage
- Capacitor class
- Approval marks
- Manufacturing date code
- IEC climatic category
- Passive flammability class
- Manufacturing date code

Packaging Quantities

Lead Spacing (mm)	Thickness (mm)	Height (mm)	Length (mm)	Bulk Short Leads	Bulk Long Leads	Large Reel ∅ 500 mm
27.5	9	17	32	816	408	450
	10	20	32	600	360	350
	11	20	32	560	336	350
	13	22	32	480	288	300
	13	25	32	480	288	
	14	28	32	352	176	
	15	24.5	32	400	240	
	18	33	32	256	128	
	22	37	32	168	112	
37.5	11	22	41.5	420	252	
	13	24	41.5	360	216	
	16	28.5	41.5	216	108	
	19	32	41.5	192	96	
	20	40	41.5	126	84	
	24	44	41.5	108	72	
	30	45	41.5	90	60	

Lead Taping & Packaging (IEC 60286-2)

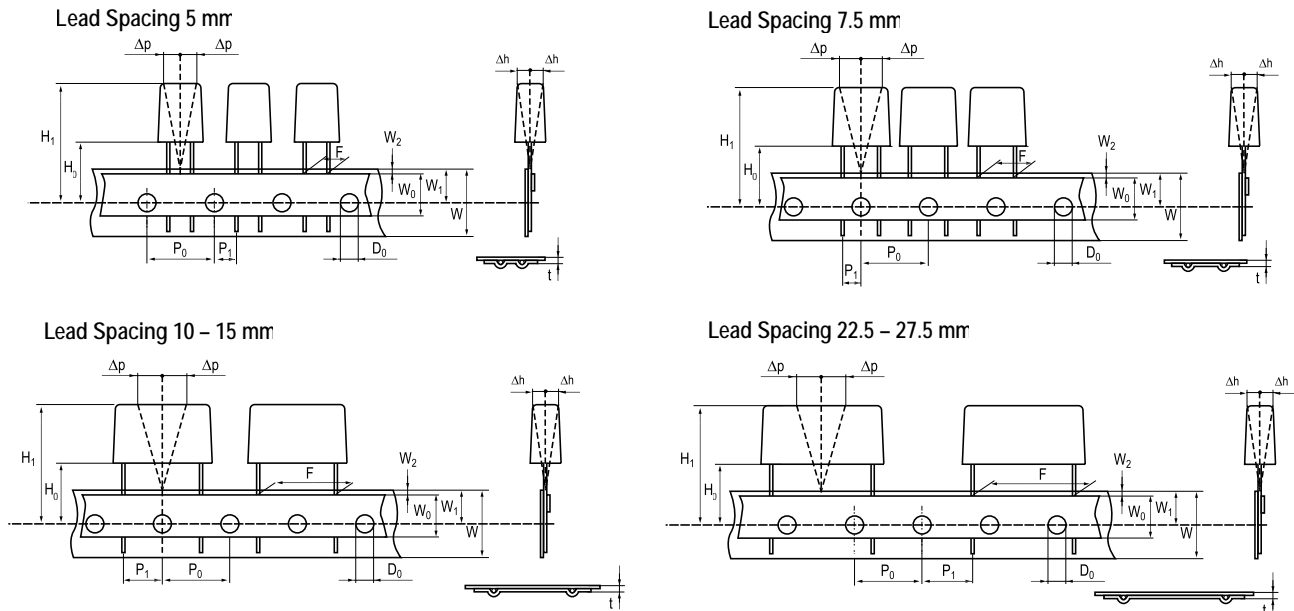

Taping Specification

Dimensions in mm									Standard IEC 60286-2
Lead spacing	+6/-0.1	F	5	7.5	10	15	22.5	27.5	F
Carrier tape width	+1/-0.5	W	18	18	18	18	18	18	18 ^{+1/-0.5}
Hold-down tape width	MIN	W ₀	6	6	9	10	10	10	
Position of sprocket hole	+/-0.5	W ₁	9	9	9	9	9	9	9 ^{+0.75/-0.5}
Distance between tapes	MAX	W ₂	3	3	3	3	3	3	3
Sprocket hole diameter	+/-0.2	D ₀	4	4	4	4	4	4	4
Feed hole lead spacing	+/-0.2 ⁽¹⁾	P ₀ ⁽³⁾	12.7	12.7	12.7	12.7	12.7	12.7	12.7
Distance lead - feed hole	+/-0.7	P ₁	3.85	3.75	7.7	5.2	7.8	5.3	P ¹
Deviation tape - plane	MAX	Δp	1.3	1.3	1.3	1.3	1.3	1.3	1.3
Lateral deviation	+/-2	Δh	2	2	2	2	2	2	2
Total thickness	+/-0.2	t	0.7	0.7	0.7	0.7	0.9 ^{MAX}	0.9 ^{MAX}	0.9 ^{MAX}
Sprocket hole/cap body	+/-0.5	H ₀ ⁽²⁾	18.5 ^{+/-0.5}	18.5 ^{+/-0.5}	18.5 ^{+/-0.5}	18.5 ^{+/-0.5}	18.5 ^{+/-0.5}	18.5 ^{+/-0.5}	18 ^{+2/-0}

(1) Maximum cumulative feed hole error, 1 mm per 20 parts.

(2) 16.5 mm available on request.

(3) 15 mm available on request (F ≥ 10 mm).

Lead Taping & Packaging (IEC 60286–2) cont'd

Ammo Specifications

Series	Dimensions (mm)		
	H	W	T
R4x, R4x+R, R7x, RSB	360	340	59
F5A, F5B, F5D			
F6xx, F8xx			
PHExxx, PMExxx, PMRxxx	330	330	50

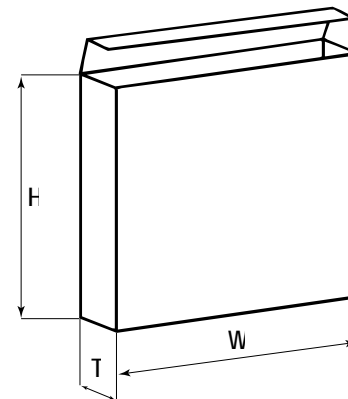

Reel Specifications

Series	Dimensions (mm)		
	D	H	W
R4x, R4x+R, R7x, RSB	355 500	30	55 (Max)
F5A, F5B, F5D		25	
F6xx, F8xx			
PHExxx, PMExxx, PMRxxx	360 500	30	46 (Max)

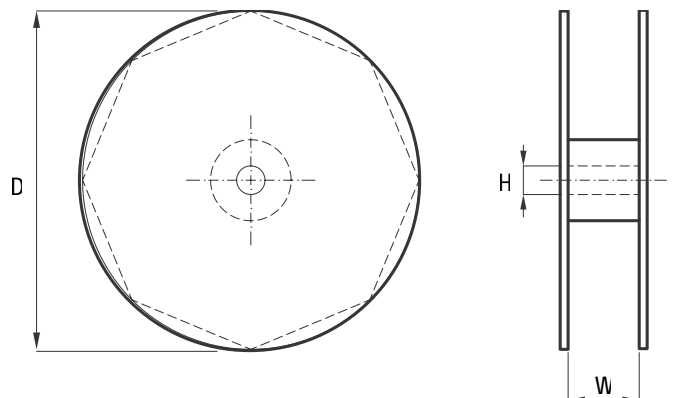

Manufacturing Date Code (IEC–60062)

Y = Year, Z = Month			
Year	Code	Month	Code
2000	M	January	1
2001	N	February	2
2002	P	March	3
2003	R	April	4
2004	S	May	5
2005	T	June	6
2006	U	July	7
2007	V	August	8
2008	W	September	9
2009	X	October	O
2010	A	November	N
2011	B	December	D
2012	C		
2013	D		
2014	E		
2015	F		
2016	H		
2017	J		
2018	K		
2019	L		
2020	M		

KEMET Corporation World Headquarters

2835 KEMET Way
Simpsonville, SC 29681

Mailing Address:
P.O. Box 5928
Greenville, SC 29606

www.kemet.com
Tel: 864-963-6300
Fax: 864-963-6521

Corporate Offices

Fort Lauderdale, FL
Tel: 954-766-2800

North America

Southeast

Lake Mary, FL
Tel: 407-855-8886

Northeast

Wilmington, MA
Tel: 978-658-1663

West Chester, PA
Tel: 610-692-4642

Central

Novi, MI
Tel: 248-994-1030

Carmel, IN
Tel: 317-706-6742

West

Milpitas, CA
Tel: 408-433-9950

Mexico

Zapopan, Jalisco
Tel: 52-33-3123-2141

Europe

Southern Europe

Geneva, Switzerland
Tel: 41-22-715-0100

Paris, France
Tel: 33-1-4646-1009

Sasso Marconi, Italy
Tel: 39-051-939111

Milan, Italy
Tel: 39-02-57518176

Rome, Italy
Tel: 39-06-23231718

Madrid, Spain
Tel: 34-91-804-4303

Central Europe

Landsberg, Germany
Tel: 49-8191-3350800

Dortmund, Germany
Tel: 49-2307-3619672

Kwidzyn, Poland
Tel: 48-55-279-7025

Northern Europe

Bishop's Stortford, United Kingdom
Tel: 44-1279-757201

Weymouth, United Kingdom
Tel: 44-1305-830747

Coatbridge, Scotland
Tel: 44-1236-434455

Färjestaden, Sweden
Tel: 46-485-563934

Espoo, Finland
Tel: 358-9-5406-5000

Asia

Northeast Asia

Hong Kong
Tel: 852-2305-1168

Shenzhen, China
Tel: 86-755-2518-1306

Beijing, China
Tel: 86-10-5829-1711

Shanghai, China
Tel: 86-21-6447-0707

Taipei, Taiwan
Tel: 886-2-27528585

Southeast Asia

Singapore
Tel: 65-6586-1900

Penang, Malaysia
Tel: 60-4-6430200

Bangalore, India
Tel: 91-806-53-76817

Note: KEMET reserves the right to modify minor details of internal and external construction at any time in the interest of product improvement. KEMET does not assume any responsibility for infringement that might result from the use of KEMET Capacitors in potential circuit designs. KEMET is a registered trademark of KEMET Electronics Corporation.

Other KEMET Resources

Tools	
Resource	Location
Configure A Part: CapEdge	http://capacitoredge.kemet.com
SPICE & FIT Software	http://www.kemet.com/spice
Search Our FAQs: KnowledgeEdge	http://www.kemet.com/keask

Product Information	
Resource	Location
Products	http://www.kemet.com/products
Technical Resources (Including Soldering Techniques)	http://www.kemet.com/technicalpapers
RoHS Statement	http://www.kemet.com/rohs
Quality Documents	http://www.kemet.com/qualitydocuments

Product Request	
Resource	Location
Sample Request	http://www.kemet.com/sample
Engineering Kit Request	http://www.kemet.com/kits

Contact	
Resource	Location
Website	www.kemet.com
Contact Us	http://www.kemet.com/contact
Investor Relations	http://www.kemet.com/ir
Call Us	1-877-MyKEMET
Twitter	http://twitter.com/kemetcapacitors

Disclaimer

All product specifications, statements, information and data (collectively, the "Information") are subject to change without notice.

All Information given herein is believed to be accurate and reliable, but is presented without guarantee, warranty, or responsibility of any kind, expressed or implied.

Statements of suitability for certain applications are based on our knowledge of typical operating conditions for such applications, but are not intended to constitute – and we specifically disclaim – any warranty concerning suitability for a specific customer application or use. This Information is intended for use only by customers who have the requisite experience and capability to determine the correct products for their application. Any technical advice inferred from this Information or otherwise provided by us with reference to the use of our products is given gratis, and we assume no obligation or liability for the advice given or results obtained.

Although we design and manufacture our products to the most stringent quality and safety standards, given the current state of the art, isolated component failures may still occur. Accordingly, customer applications which require a high degree of reliability or safety should employ suitable designs or other safeguards (such as installation of protective circuitry or redundancies) in order to ensure that the failure of an electrical component does not result in a risk of personal injury or property damage.

Although all product-related warnings, cautions and notes must be observed, the customer should not assume that all safety measures are indicated or that other measures may not be required.

