

TECHNICAL DATA

| | |
|--|---|
| Service: | Continuous |
| Operating temperature | -25 ... +55°C |
| Storage temperature | -40 ... +85°C |
| Life Expectancy | ≥ 100.000 Hours at U_{RMS} |
| Dielectric Dissipation Factor $tg\delta_0$ | 2×10^{-4} |
| Capacitance tolerance | -5 ... +15% (X) |
| Test voltage terminal to case U_{TT} | $2,15 U_{RMS}$ for 10 seconds |
| Test voltage terminal to case U_{TC} | $U_{RMS} < 690[V\sim]$: 3KV - 50Hz for 10 seconds $U_{RMS} \geq 690[V\sim]$: 6kV - 50Hz for 10 seconds |
| Rated power Q | Reactive power at rated A.C. voltage $U_{RMS} - F_N$ |
| Max admissible voltage: | 1.1 times the nominal voltage 8h / 24h |
| Max admissible current: | 1.3 times the nominal current I_N |
| Permissible relative humidity | Annual average ≤ 95% on 30 days / year, continuously 100% on other days occasionally 100%. Dewing not admissible |
| Degree of protection | IP30 |
| Capacitance deviation | ±1.5% max on cap. value measured at +20 °C |
| Installation | Whatever Position |
| Safety: | Overpressure safety device |

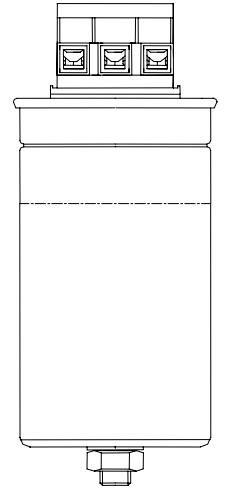

GENERAL CHARACTERISTICS

| Code | C | Q | U_{RMS} | dv/dt | Freq | I_N | Dimensions | |
|-----------------|---------|------|-----------|-------|------|-------|------------|-------|
| | µF | kvar | V_{ac} | V/µs | Hz | A | Slim | Conc. |
| C9T_5AD5308AA0X | 3*30.8 | 5 | 415 | 30 | 50 | 7.0 | A | G |
| C9T_5AD5462AA0X | 3*46.2 | 7.5 | 415 | 30 | 50 | 10.4 | A | H |
| C9T_5BD5616AA0X | 3*61.6 | 10 | 415 | 30 | 50 | 13.9 | B | I |
| C9T_5MD5770AA0X | 3*77 | 12.5 | 415 | 30 | 50 | 17.4 | C | J |
| C9T_5MD5924AA0X | 3*92.4 | 15 | 415 | 30 | 50 | 20.9 | C | K |
| C9T_5MD6108AA0X | 3*108 | 17.5 | 415 | 30 | 50 | 24.3 | D | L |
| C9T_5MD6123AA0X | 3*123.2 | 20 | 415 | 30 | 50 | 27.8 | D | M |
| C9T_5MD6154AA0X | 3*154 | 25 | 415 | 30 | 50 | 34.7 | E | N |
| C9T_5MD6185AA0X | 3*184.8 | 30 | 415 | 30 | 50 | 41.7 | F | O |
| C9T_6AD5262AA0x | 3*26.2 | 5 | 450 | 30 | 50 | 6.4 | A | G |
| C9T_6AD5393AA0X | 3*39.3 | 7.5 | 450 | 30 | 50 | 9.6 | A | H |
| C9T_6BD5524AA0X | 3*52.4 | 10 | 450 | 30 | 50 | 12.8 | B | I |
| C9T_6MD5655AA0X | 3*65.5 | 12.5 | 450 | 30 | 50 | 16.0 | C | J |
| C9T_6MD5786AA0X | 3*78.6 | 15 | 450 | 30 | 50 | 19.2 | C | K |
| C9T_6MD5917AA0X | 3*91.7 | 17.5 | 450 | 30 | 50 | 22.5 | D | L |
| C9T_6MD6105AA0X | 3*105 | 20 | 450 | 30 | 50 | 25.7 | D | M |
| C9T_6MD6131AA0X | 3*131 | 25 | 450 | 30 | 50 | 32.0 | E | N |
| C9T_6MD6157AA0X | 3*157 | 30 | 450 | 30 | 50 | 38.5 | F | O |
| C9T_AAD5192AA0X | 3*19.2 | 5 | 525 | 30 | 50 | 5.5 | A | G |
| C9T_AAD5290AA0X | 3*29 | 7.5 | 525 | 30 | 50 | 8.3 | A | H |
| C9T_ABD5385AA0X | 3*38.5 | 10 | 525 | 30 | 50 | 11.0 | B | I |
| C9T_AMD5481AA0X | 3*48.1 | 12.5 | 525 | 30 | 50 | 13.7 | C | J |
| C9T_AMD5577AA0X | 3*57.7 | 15 | 525 | 30 | 50 | 16.5 | C | K |
| C9T_AMD5674AA0X | 3*67.4 | 17.5 | 525 | 30 | 50 | 19.2 | D | L |
| C9T_AMD5770AA0X | 3*77 | 20 | 525 | 30 | 50 | 22.0 | D | M |
| C9T_AMD5962AA0X | 3*96.2 | 25 | 525 | 30 | 50 | 27.5 | E | N |
| C9T_AMD6115AA0X | 3*115 | 30 | 525 | 30 | 50 | 33.0 | F | O |
| C9T_DBD5279AA0X | 3*27.9 | 12.5 | 690 | 30 | 50 | 10.5 | B | J |
| C9T_DMD5334AA0X | 3*33.4 | 15 | 690 | 30 | 50 | 12.6 | D | K |
| C9T_DMD5390AA0X | 3*39 | 17.5 | 690 | 30 | 50 | 14.6 | D | L |
| C9T_DMD5446AA0X | 3*44.6 | 20 | 690 | 30 | 50 | 16.7 | E | M |
| C9T_DMD5557AA0X | 3*55.7 | 25 | 690 | 30 | 50 | 20.9 | E | N |
| C9T_DMD5668AA0X | 3*66.8 | 30 | 690 | 30 | 50 | 25.1 | F | O |

Reference Standards:
IEC 831-1 / 2

Protected 1000 AFC
-25°C ... +70°C

Statements of suitability for certain applications are based on our knowledge of typical operating conditions for such applications, but are not intended to constitute – and we specifically disclaim – any warranty concerning suitability for a specific customer application or use. This Information is intended for use only by customers who have the requisite experience and capability to determine the correct products for their application. Any technical advice inferred from this Information or otherwise provided by us with reference to the use of our products is given gratis, and we assume no obligation or liability for the advice given or results obtained.

DIMENSIONS & PACKAGING

| Dim | Case | | | Style | SPQ |
|-----|------|-------|------|-------|-----|
| | D mm | D1 mm | H mm | | |
| A | 60 | 64 | 220 | 3 | 9 |
| B | 65 | 69 | 220 | 2 | 9 |
| C | 75 | 79 | 220 | 1 | 9 |
| D | 75 | 79 | 280 | 1 | 9 |
| E | 85 | 89 | 280 | 1 | 5 |
| F | 95 | 99 | 280 | 1 | 4 |
| G | 65 | 69 | 150 | 2 | 9 |
| H | 65 | 69 | 175 | 2 | 9 |
| I | 75 | 79 | 175 | 2 | 9 |
| J | 75 | 79 | 200 | 1 | 9 |
| K | 85 | 89 | 200 | 1 | 5 |
| L | 95 | 99 | 175 | 1 | 4 |
| M | 95 | 99 | 200 | 1 | 4 |
| N | 116 | 120 | 175 | 1 | 4 |
| O | 116 | 120 | 200 | 1 | 4 |

CODE STRUCTURE

| 4 th dgt | Type |
|---------------------|------------|
| S | Slim |
| C | Concentric |

| 5 th dgt | Rated Voltage |
|---------------------|---------------|
| 5 | 415 |
| 6 | 450 |
| A | 525 |
| D | 690 |

| 6 th dgt | Terminal Style |
|---------------------|----------------|
| A | 3 |
| B | 2 |
| M | 1 |
| T | 4 |

| 7 th dgt | Internal Connection |
|---------------------|---------------------|
| D | DELTA |
| Y | STAR |

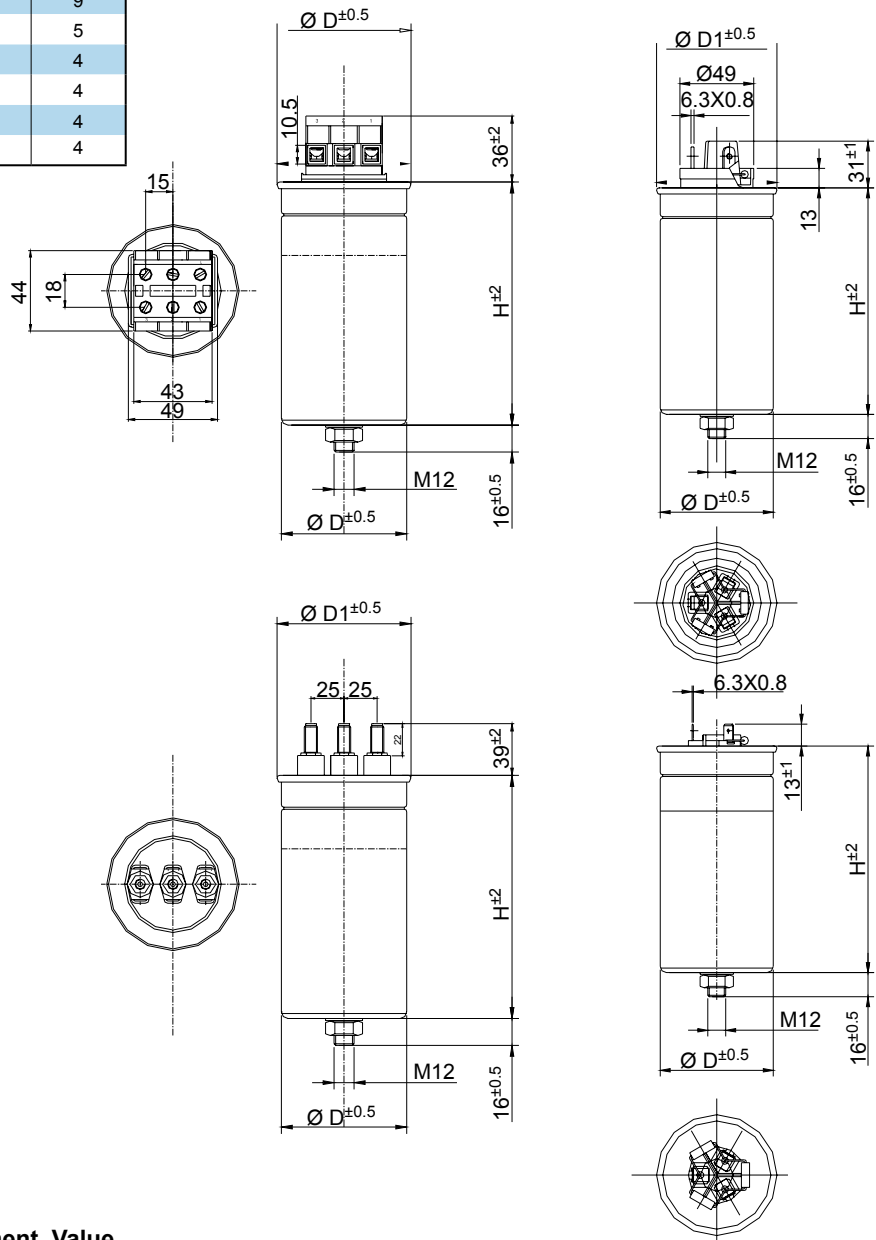

8th - 11th dgt → Single Capacitive Element Value

Statements of suitability for certain applications are based on our knowledge of typical operating conditions for such applications, but are not intended to constitute – and we specifically disclaim – any warranty concerning suitability for a specific customer application or use. This Information is intended for use only by customers who have the requisite experience and capability to determine the correct products for their application. Any technical advice inferred from this Information or otherwise provided by us with reference to the use of our products is given gratis, and we assume no obligation or liability for the advice given or results obtained.