

# Introduction to Capacitor Technologies

What is a Capacitor?

2013

## Table of Contents

Introduction .....	3
Capacitor Construction, Parameters and Properties .....	3
Capacitor Construction .....	3
Capacitor Parameters .....	4
Dielectric Characteristics and Capacitor CV .....	6
Capacitor Properties .....	6
A Capacitor Water Tank Analogy .....	6
Practical Capacitance .....	7
Leakage Current vs. Insulation Resistance .....	7
Charge/Discharge Behavior .....	8
Dielectric Strength .....	9
Dissipation of Energy .....	9
Inductance .....	10
Equivalent Circuit Description of the Capacitor .....	11
Capacitor Technologies .....	12
Uses of Capacitors .....	13
Decoupling .....	13
Filtering .....	13
Coupling .....	13
Timing and Waveshaping .....	14
Oscillators .....	14
Overview of Major Capacitor Applications .....	14
Summary: Capacitor Selection for Performance and Quality .....	15
Glossary of Terms .....	15
More about KEMET .....	16

## Introduction

Capacitors are electronic components that store, filter and regulate electrical energy and current flow and are one of the essential passive components used in circuit boards. Capacitors are primarily used for storing electrical charges, conducting alternating current (AC), and blocking or separating different voltages levels of direct current (DC) source.

While capacitors are one type of component, there are many types of capacitors that are differentiated by the materials used in construction, each providing unique features and benefits. Understanding basic capacitor construction and how different materials can affect their characteristics will aid in choosing the proper capacitor for a given application.

The unit of capacitance is the farad. For 1 farad of capacitance, 1 coulomb of charge is stored on the plates when 1 volt is applied:

$$1 \text{ farad} = 1 \text{ coulomb} / 1 \text{ volt}$$

$$1 \text{ coulomb represents } \sim 6 \times 10^{19} \text{ electrons}$$

## Capacitor Construction, Parameters and Properties

### Capacitor Construction

All capacitors are formed with the same basic structure. Two parallel metal electrode plates are separated by a non-conductive material called the dielectric. When a voltage exists between these conductive parallel plates, an electric field is present in the dielectric. This field stores energy and produces a mechanical force between the plates.

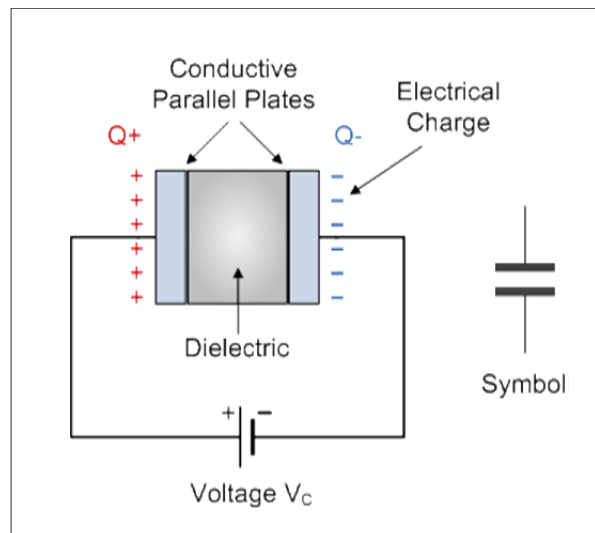

Figure 1: Basic structure of a capacitor.

## Capacitor Parameters

The amount of capacitance  $C$  for a parallel plate capacitor is determined by the equation:

$$C = \epsilon * A / d$$

Where  $A$  = plate area,  $d$  = distance between plates, and  $\epsilon$  = dielectric material constant.

Also note that:

$\epsilon$  = relative dielectric constant x dielectric constant of vacuum =  $\epsilon_r \times \epsilon_0$

Where:  $\epsilon_r$  is a plain number,  $\epsilon_0 = 8.85 \times 10^{-12}$  F/m

This general formula shows that:

1. the larger the plate area, the larger the capacitance value
2. the smaller distance between the plates, the larger capacitance value
3. the larger the dielectric constant of the insulating (dielectric) material, the larger the capacitance

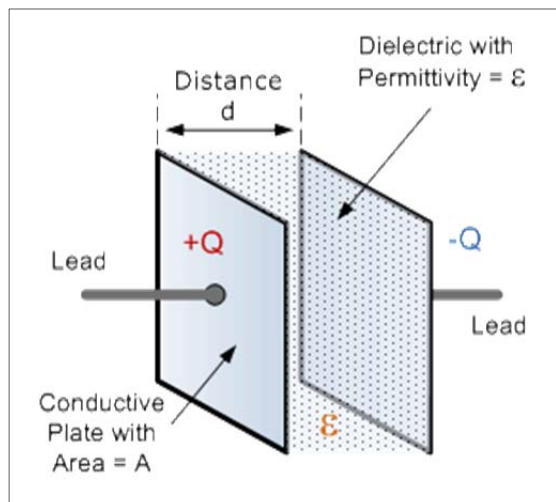

Figure 2: Capacitance parameters.

Since many materials can be used as the dielectric, Figure 3 outlines the dielectric constants of some of the more commonly used materials.

Dielectric Material	Dielectric Constant
Vacuum	1
Air	1.0006
Polypropylene PP	2.2
Polyphenylene Sulfide PPS	3
Polyester PET	3.3
Polyester PEN	3.0
Impregnated Paper	2.0 – 6.0
Mica	6.8
Aluminum Oxide	8.5
Tantalum Oxide	27.7
Paraelectric Ceramics (Class 1)	5 – 90
Barium Titanate (Class 2)	3000 – 8000

Figure 3: Dielectric constants of commonly used materials.

Taking into account the physical characteristics of the electrode plates, the distance between the plates, and the various dielectric constants, the normal ranges of values for various types of capacitors is shown in Figure 4.

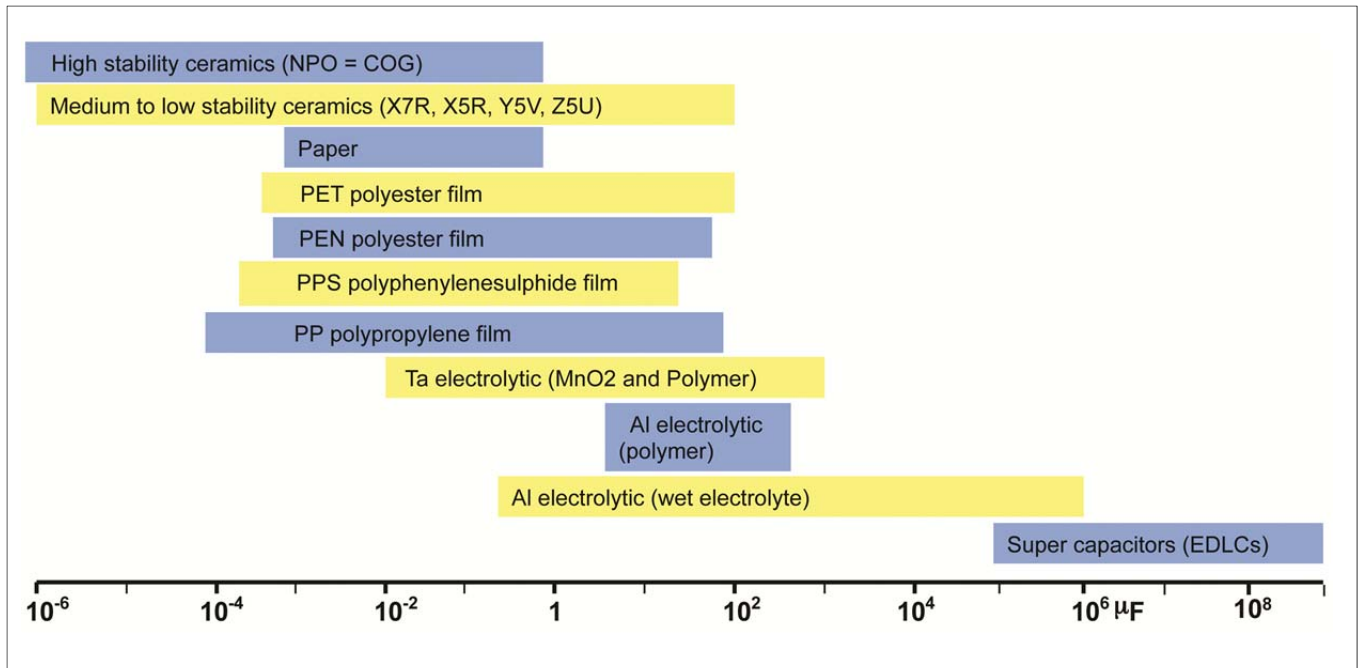

Figure 4: Values of capacitors by dielectric.

## Dielectric Characteristics and Capacitor CV

The properties of the dielectric also influence the volumetric efficiency of the capacitor. This is an important consideration when designing portable systems or very densely populated circuit boards, where high capacitance is required within small component dimensions. Volumetric efficiency is the amount of capacitance that can be provided within a given volume, and is expressed as a CV value where C is capacitance and V is voltage. A high CV is required for high volumetric efficiency. Tantalum dielectrics are known for their high CV properties. Optimizing the physical design of the capacitor, for example by maximizing the usable electrode surface area and minimizing package overheads, also helps increase the CV of the end product.

## Capacitor Properties

An ideal capacitor has exactly the desired capacitance value and it is a perfect insulator. However, practical considerations must be taken into account for both the capacitance value and amount of insulation provided by a given capacitor.

1. The capacitor can store electric energy (as discussed earlier, the capacitance value determines the amount of charge, or energy, at given voltage)
2. The capacitor can separate different DC voltage levels from each other, but also conducts AC current
3. In general, the higher the frequency of AC voltage, the better the capacitor conducts the AC current

### A Capacitor Water Tank Analogy

Consider two water tanks, one larger and one smaller, connected to each other with both a pipe and a rubber membrane closing the pipe. This membrane acts like a capacitor, separating the high water level in the larger tank (high voltage) from low water level in the smaller tank (low voltage).

If there are water tight pistons resting on the water in both tanks, and one piston is moved down and up, the membrane is bending causing the other piston to move up and down. Thus, alternating movement (voltage) is transferred through the membrane (capacitor) although no water (direct current) is flowing from one tank to another.

The leakage current resembles a small hole in the membrane causing water to leak from higher water level tank to lower water level tank.

The analogy of dielectric strength is the mechanical strength of the membrane in the water pipe. Under high water pressure, the membrane can break.

## Practical Capacitance

While capacitors have a rated capacitance, there are a number of factors to consider in determining a capacitor's usable capacitance. The dielectric material may cause a change in the capacitance value depending on:

- Temperature
- Humidity
- DC voltage
- AC voltage
- Signal frequency
- Age of the capacitor
- Mechanical
- Piezoelectric effect

When selecting a particular capacitor, these properties must be taken into consideration.

Every capacitor is rated with a certain tolerance around its nominal value. Typically, the tolerance is coded using letters. The most common tolerance codes are:

± 20% = M	± 2.5% = H
± 10% = K	± 2% = G
± 5% = J	± 1% = F

The standard values used for manufacturing capacitors are based on the "E-series" like E6 and E12. This means capacitors have nominal capacitances such as the following,

E6 series: 1, 1.5, 2.2, 3.3, 4.7 and 6.8 and their decimal multiples (10, 15, 220, etc.)

E12 series: 1, 1.2, 1.5, 1.8, 2.2, 2.7, 3.3, 3.9, 4.7, 5.6, 6.8, 8.2 and their decimal multiples

## Leakage Current vs. Insulation Resistance

The dielectric materials used in capacitors are not ideal insulators. A small DC current can flow, or "leak" through the dielectric material for various reasons specific to each dielectric. As a result, when a capacitor is charged to a certain voltage, it will slowly lose its charge. As it loses its charge, the voltage between the capacitor's electrodes will drop.

The leakage current (LC) and the insulation resistance (IR) are in simple mathematical relation to each other:

$$R \text{ (IR)} = V / I \text{ (LC)} \quad \text{or} \quad I \text{ (LC)} = V / R \text{ (IR)}$$

Since the values are related, the usage of the terms leakage current and insulation resistance will vary depending on the dielectric type. Aluminum electrolytic capacitors have a relatively large leakage which is thus referred to as leakage current. Alternatively, plastic film or ceramic capacitors have a very small leakage current, so the effect is quantified as an insulation resistance.

Generally, insulation resistance tends to decrease with higher values of capacitance. For practical reasons the insulation resistance may be expressed in Megaohms at low capacitance values, and in Ohm-Farads (equals seconds) at higher capacitances. The Ohm-Farad expression allows a single figure to be used to describe the insulation performance of a given component family over a wide range of capacitance values.

The leakage current is also dependent on the temperature. As the temperature increases, so does the leakage current.

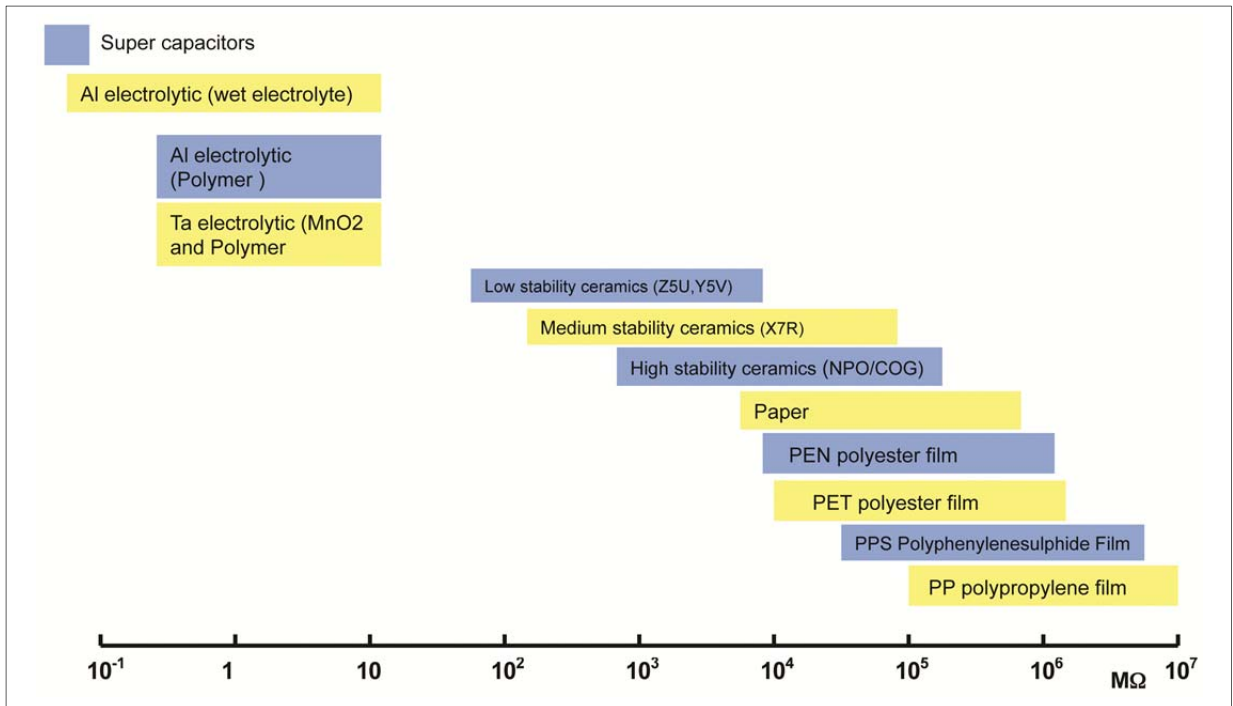

Figure 5: Values of capacitor types relative to dielectric Insulation Resistance (IR).

### Charge/Discharge Behavior

When a DC voltage is applied to a capacitor connected in series with a resistor, the capacitor begins to charge at a rate according to the applied voltage, the state of charge relative to its final value, the series resistance, and its own capacitance. The product of the resistance and capacitance is referred to as the time constant ( $\tau = R \times C$ ) of the circuit. Actually, it is the time required to charge the capacitor by 63.2% of the difference between the initial value and the final value. Hence, the value of charge plotted against time follows the curve shown in Figure 6. During this time, the charging current follows the red curve also shown in Figure 6.

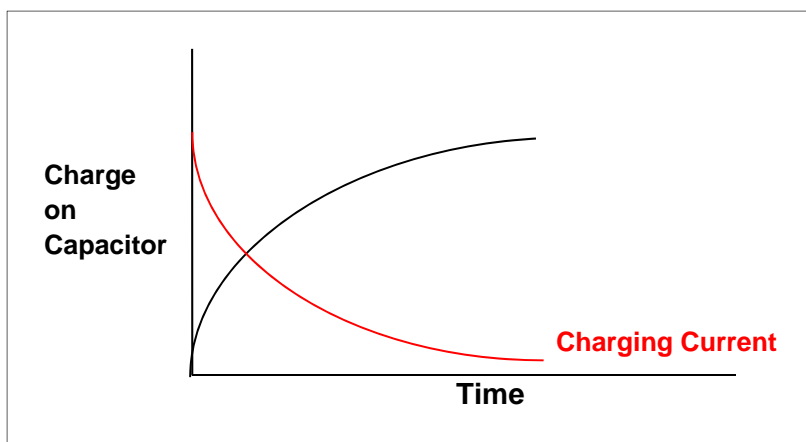

Figure 6. Charging a capacitor through a series resistance.



The charge on the capacitor at any time,  $t$ , is calculated by the following equation:

$$Q = C \times V \times [1 - e^{-t/RC}]$$

The charging current decays according to the equation:

$$I = V/R \times e^{-t/RC}$$

Where  $e = 2.7182818$ , the so-called “natural number,” or the base of natural logarithm,  $\ln(x)$ .

Many physical and even economical phenomena can be explained and described by using exponential or logarithmic functions.

Note that in practice, the charging current does not reach zero and tends towards a small finite value equivalent to the capacitor’s leakage current.

Similarly, the time constant ( $\tau = R \times C$ ) also governs the time to discharge the capacitor through the series resistance.

### Dielectric Strength

When voltage is continuously increased over the capacitor, the dielectric material will at some point not withstand the electric field between the electrodes, causing the dielectric to break down. The breakdown areas in the dielectric may become permanently conductive due to various compounds, such as carbon compounds, which are formed during the breakdown. After this occurs, the capacitor is no longer functional and is considered to be a “short circuit” or an “insulation resistance reject.”

Depending on the dielectric and electrode construction, it may be possible for a capacitor to “heal” itself. For example, film and paper capacitors with very thin electrodes ( $1/1000^{\text{th}}$  the diameter of a human hair) are able to self-heal. This self-healing occurs as the large current flowing through the breakdown area heats up the electrode layers. Metals evaporate and oxidize away from this area, thus isolating the short circuit path from the rest of the capacitor. This process can occur even in very high-power applications up to several kilowatts.

Wet electrolytic capacitors such as aluminum electrolytic capacitors rely on the electrolyte to continuously recover small breakdowns in dielectric. Solid electrolyte capacitors including those made from tantalum self-heal through chemical changes in the cathode material.

### Dissipation of Energy

Dissipation of energy is an alternating voltage/current-related parameter. An ideal capacitor has no dissipation.

When AC voltage is applied to a capacitor, current starts to flow through its dielectric material and all of its conductive parts such as electrodes and lead wires/terminations. In a practical capacitor, some part of the current passing through the capacitor is dissipated because there is a small amount of resistance to the flow of current. This dissipation of energy is manifested as temperature increase in the capacitor.

The capacitor’s overall resistance, called Equivalent Series Resistance (ESR), which causes the dissipation of energy, is a sum of two elements:

1. Resistance of the dielectric material
2. Resistance of the conductive parts

Each dielectric material has a Dissipation Factor (DF), which is material-specific, and can vary considerably between the materials. DF is frequency-dependent and displays a small increase with increasing frequency.

The resistance of the dielectric material (part of the total ESR) of the capacitor is determined by the material-specific DF and the capacitance value, and is also frequency dependent. This part of ESR is high at low frequencies and decreases with increasing frequency.

The resistance of the conductive parts (also part of the total ESR) is similar to a resistor, which has a constant value, not depending on frequency. This can be called “ohmic resistivity,” staying constant from low to high frequencies. Because the dielectric part of ESR is high at low frequencies and decreases with frequency, and the ohmic part of ESR is constant over frequency, the first one dominates on low frequencies while the latter dominates on high frequencies.

Figure 7 compares the energy dissipation properties of various common capacitor dielectrics. Polypropylene film capacitors can be a good choice in circuits that require very high energy efficiency, since the dielectric has a very low dissipation factor. Aluminum electrolytic capacitors may warm up considerably in some applications, and it is important to ensure they are properly cooled.

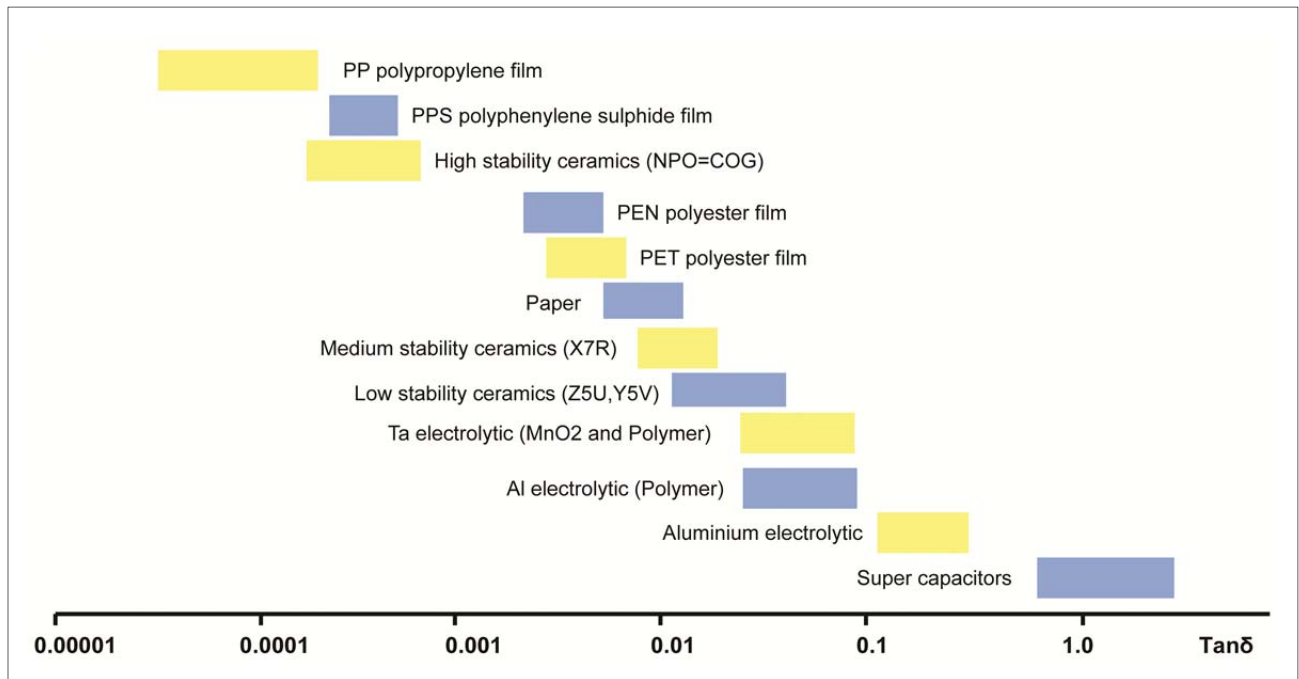

Figure 7: Dissipation factors ( $Tan\delta$ ) of various dielectrics.

### Inductance

The electrodes and lead wires or terminations of a capacitor are formed from metal conductors. All metal conductors have some inductance associated with them. This inductance is always larger when the electric path via the capacitor is longer, i.e., the lead wires and/or the capacitor body are longer. The inductance tends to resist the changes in the AC current through the capacitor.

### Equivalent Circuit Description of the Capacitor

The conductive parts also have an associated ohmic resistance, which combined with the dielectric resistance, form Equivalent Series Resistance (ESR). A practical, real capacitor can be described by using a so-called equivalent circuit, where a resistor (ESR) and an inductor (ESL) are in series with a pure capacitance in parallel and a resistor equal to the insulation resistance of the dielectric. This equivalent circuit is depicted in Figure 8.

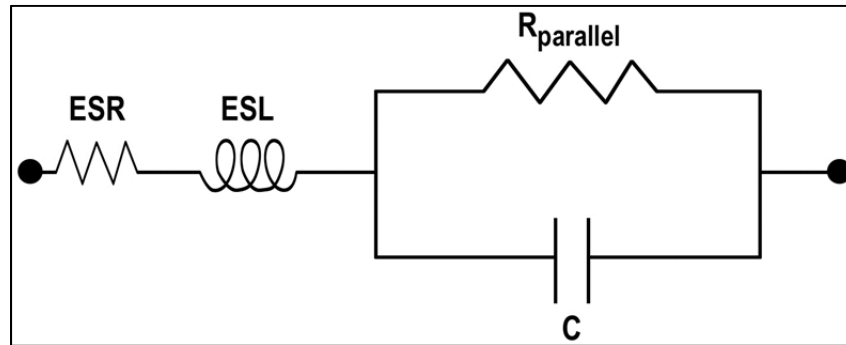

Figure 8.: Equivalent circuit of a capacitor, taking into account parasitic inductance and resistance effects.

Both a capacitor and an inductor are frequency-dependent impedances (AC resistances) for alternating current. This parameter is called either capacitive or inductive reactance.

The capacitive reactance  $X_C$  is calculated with the formula:

$$X_C = 1 / 2\pi fC$$

When frequency increases for a given ideal capacitor (C-value constant) the  $X_C$  decreases approaching zero.

The inductive reactance  $X_L$  is calculated with the formula:

$$X_L = 2\pi fL$$

When frequency is zero,  $X_L$  is zero, and when frequency increases, the  $X_L$  increases.

Normally, the inductance in capacitors is small ( 1– 20 nH), and its influence can generally be seen only at high frequencies.

The frequency at which the capacitance and inductance of a capacitor cause equally large but opposite reactance is called the self-resonance frequency. At the self-resonance frequency, the capacitive and inductive reactance cancels each other out, and the ESR seen by the circuit is due only to the purely resistive parts of the capacitor.

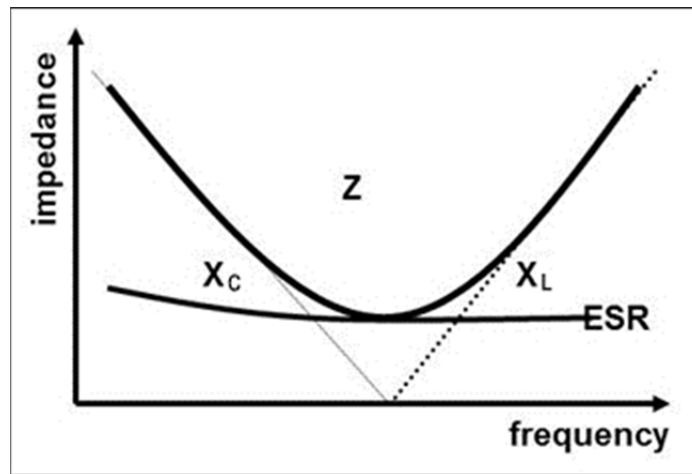

Figure 9: At self-resonance, the impedance curve and the ESR curve are asymptotic

### Capacitor Technologies

Capacitors can be divided in two basic groups: electrostatic capacitors and electrolytic capacitors. Electrostatic capacitors are symmetrical non-polar constructions. Materials such as plastic film and ceramic are used as the dielectric, while a variety of metals are used as electrodes. Since these parts are not polarized, they can generally be inserted into a circuit without regard to which points the terminals are connected.

Electrolytic capacitors, on the other hand, do have asymmetric and polarized construction. Electrolytic capacitors utilize an electrolyte which may maintain the dielectric layer and also create the negative connection, or cathode. Metal foils or powders, such as aluminum and tantalum, are used to form the positive connection (anode). The dielectric layer is created by forming a thin oxide on the metal anode. For example, in aluminum electrolytic capacitors, the anode is aluminum, the dielectric is aluminum oxide, and the liquid electrolyte is also the cathode. Since these capacitors are polarized, care must be taken to ensure they are designed and inserted correctly into circuits.

Typically, the benefit of using electrolytic capacitors is that they can have relatively large capacitance values in a reasonable size. Electrostatic style capacitors are generally used for small or precision capacitance values.

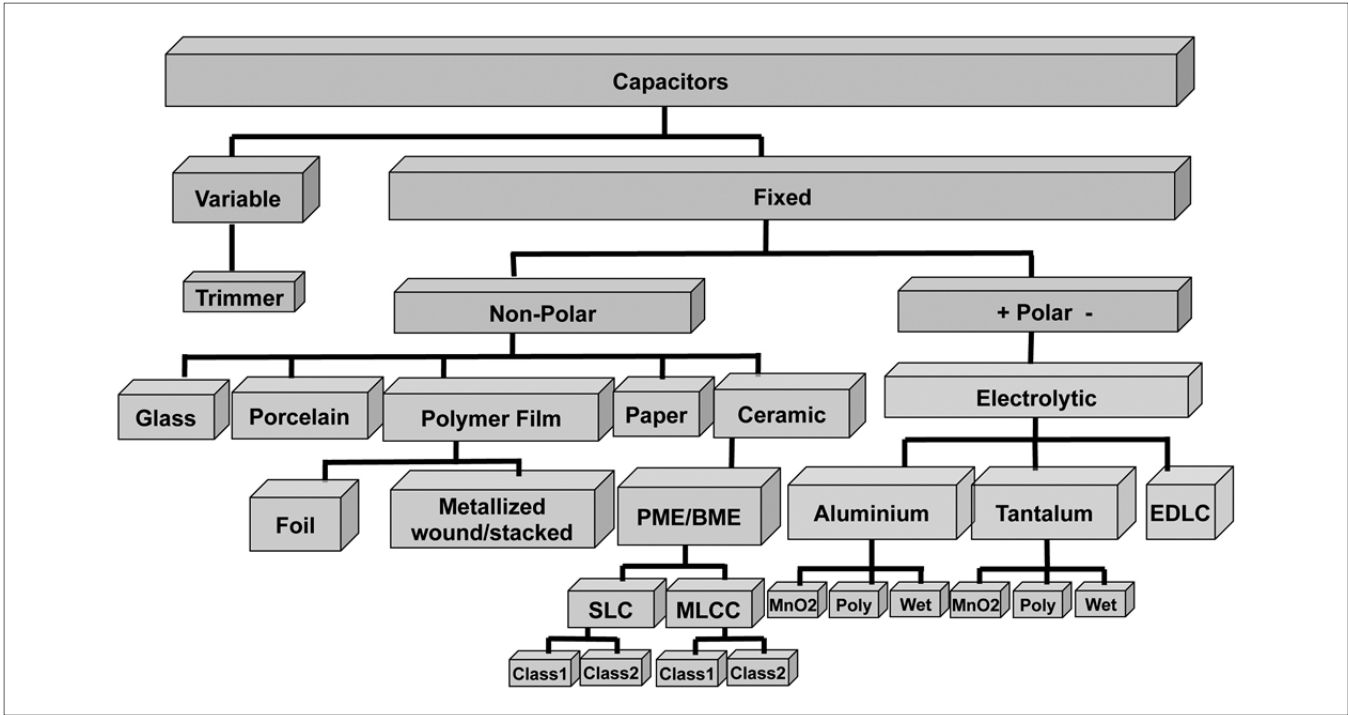

Figure 10: Overview of capacitor technologies.

## Uses of Capacitors

### Decoupling

The most prevalent use of capacitors is to decouple a system, such as an integrated circuit, from sudden changes, including transfers of energy, within the power supply. Connecting a decoupling capacitor between supply voltage connection and ground in an Integrated Circuit (IC), close to the IC itself, helps maintain a stable voltage level and supply fast power to the IC when needed.

### Filtering

The second most common capacitor application is in filtering to remove signals at unwanted frequencies. By exploiting the capacitor's inherently high impedance at low frequencies, and reducing impedance at higher frequencies, a resistor-capacitor (RC) filter can be designed to remove high frequency interference such as noise in analog signals, or to protect circuitry unwanted AC voltages Applications include Class AB amplifiers, AM radios and cellular telephones Filtering is also widely used in switched-mode power supply systems and Class D amplifiers to prevent switching noise from causing interference or impairing system performance.

By combining capacitive, resistive and inductive elements (inductors display increasing resistance at higher frequencies), analog filters can be built with low-pass, high-pass, band-pass or band-stop properties with various cut-off frequencies and selectivity characteristics.

## Coupling

Because capacitors do not conduct DC currents, they are often used to separate different voltage levels from each other by blocking DC voltages. Since AC signals can pass through capacitors, this property is used in circuits such as multi-stage amplifiers. Signals are allowed to pass through, but to separate voltage levels. As an example, a weak radio signal of a few microvolts, captured by an antenna, can be fed through a capacitor to an amplifying stage operating at a higher voltage, and subsequently to following stages without overloading the sensitive first-stage components.

The capacitor's ability to remove a DC offset voltage from an alternating signal is also valuable in equipment such as electronic meters.

## Timing and Waveshaping

The manner in which a capacitor charges and discharges through a resistor can be exploited for various timing purposes, such as introducing a delay or changing the shape of a waveform. By adjusting the values of the capacitor and resistor, designers can build timing circuits for controlling the speed of various functions. Examples include windshield wiper speeds, light flashing intervals or the timing of light reaching maximum brightness after being switched on. Combined with active components like the well-known 555 timer, timing can be controlled accurately from just a few microseconds to days or weeks.

## Oscillators

Together with inductive components, capacitors can be used to build oscillators for generating accurate sinusoidal signals. Oscillators are utilized for in simple timing, in RF circuit or in musical instrument applications including synthesizers and electric guitars.

An inductor-capacitor oscillator uses the inductor to alternately charge and discharge the capacitor, thereby setting up an alternating signal with a frequency that is dependent on the capacitance and inductance values. An RC oscillator uses the capacitor to induce a phase shift by virtue of the fact that the output voltage of the RC circuit leads the input voltage by a phase angle, which in practice, is somewhat less than 90°. By combining typically three or more phase-shifting stages containing selected C and R values, sufficient phase shift can be achieved to produce oscillation at a desired frequency. With the help of active components, the accuracy or tenability of these circuits can be greatly enhanced.

### Overview of Major Capacitor Applications

1. **Decoupling**—enables sudden transfers of current (energy) while maintaining stable voltage levels.
2. **Filtering**—removes or reduces unwanted AC voltages in applications such as AM radio, cellular telephone or IC switching noise applications
3. **Coupling**—blocks DC and passes AC component, for example, in smart meter applications
4. **Timing and Waveshaping**—Sets delay time in systems such as windshield wipers

## Summary: Capacitor Selection for Performance and Quality

The capacitor is a fundamental component for influencing the behavior of electronic circuits. It has applications in both analog and digital circuits, and at voltages from less than one volt to several thousand volts.

Designers have a variety of capacitor technologies at their disposal, differentiated primarily by the type of dielectric. This influences key aspects such as the capacitance value and size (volume) of the device, as well as energy efficiency. When combined with critical dimensions including the thickness of the dielectric, the capacitor's maximum voltage rating and insulating capability can also be affected.

The differing properties of various capacitor technologies allow designers to select the optimum device type of any given application based on criteria such as operating voltage, required capacitance, device size and frequency response. Other characteristics, such as aging (drying of wet electrolyte) causing loss of capacitance, maximum recommended operating temperature, flammability and self-healing properties, are also important factors influencing device selection. In some cases, special low ESR devices that feature minimal parasitic resistance may be required, for example, to minimize power losses in high current applications.

Despite relatively low unit costs when compared to high-performance ICs, the large numbers of capacitors used throughout any given system can account for a considerable proportion of the total bill of materials (BoM). There are many sources for budget capacitors in today's market, and these can offer an attractive saving in BoM costs. However, these often tiny devices can have a significant effect on product performance, end-of-line production yield, reliability and lifetime in the field, and in some cases, safety. KEMET always recommends using high quality capacitors from a reputable source such as direct from the manufacturer or from a franchised distributor.

## Glossary of Terms

**AC** – alternating current, the movement of electrical charge periodically reversing direction.

**Capacitance** – the capability for a device to store an electrical charge.

**Coulomb** – the unit of electric charge. It is defined as the charge transported by a steady current of one ampere in one second. It is also the amount of excess charge on the positive side of a capacitance of one farad charged to a potential difference of one volt.

**Coupling** – the transfer of an AC signal from one medium or circuit block to another with no DC coupling.

**Current** – the flow of electric charge through a conductive medium.

**DC** – direct current is the unidirectional flow of electrical charge in a constant direction.

**DC leakage** – gradual loss of energy in a charged capacitor due to imperfections of the dielectric.

**Decoupling** – enabling the quick and quiet energy transfer into a device and circumventing delays and noise creation.

**ESL** – equivalent series inductance, the effective inductance that is parasitically perceived in a device.

**ESR** – equivalent series resistance, the non-ideal parasitic loss to heat due to current flow.

**Farad** – the measure of capacitance equal to the charge in coulombs a capacitor will accept for a potential of one volt applied.

**Filtering** – a way to process a signal by removing unwanted frequency components.

**Frequency** – number of occurrences of a repeating event per unit time. In electrical systems, for a sinusoidal signal of 60 Hz or 60 cycles/second, indicates that the sine wave goes through 360 degrees 60 times per second.

**Impedance** – the measure of the opposition a circuit presents to the passage of AC current.

**Low voltage DC** – Relative to the definer, an area of design below 100V, with focus on switching power supplies.

**Microfarad** – one-millionth farad or  $1 \times 10^{-6}$  farads

**Nanofarad** – one-billionth farad, or  $1 \times 10^{-9}$  farads

**Oscillation** – generation of repetitive voltages which may be of any different shapes, such as sinusoidal, triangular or square.

**Picofarad** – one-trillionth farad, or  $1 \times 10^{-12}$  farads.

**Power electronics** –the application of electronics for the control and conversion of electric power.

**Resistance** – a measure of the opposition a circuit presents to the electric current through it.

**Ripple current** – a repetitive variation in DC current.

**Surface mount** – a mounting scheme used for electronic circuits in which the components are mounted directly on the surface of the printed circuit board, usually with solder attachment.

**Through-hole** –a mounting scheme used for electronic circuits in which the component leads are inserted into holes drilled in printed circuit boards and solder attached. Also referred to as leaded.

**Voltage** – analogous to water pressure, the electrical potential difference between two points.

**Waveshaping** – acting upon a signal and changing it to another form.

## More about KEMET

Headquartered in Simpsonville, South Carolina, KEMET operates 23 production facilities in Europe, North America and Asia and employs 10,420 employees worldwide. Manufacturing facilities are located in Mexico, China, Italy, U.K., Portugal, Finland, Sweden, Indonesia, Germany, Bulgaria and Macedonia. KEMET also owns two specialty electronics companies--FELCO in Chicago, Illinois and Dectron in Farjestaden, Sweden. Sales offices and distribution centers are located around the world.

KEMET is a leading global manufacturer of the world's most complete line of surface mount and through-hole capacitor technologies across tantalum, ceramic, aluminum and film dielectrics. KEMET's customer base includes most of the world's major electronics original equipment manufacturers, manufacturing services companies, and electronics distributors. Production is measured at over 30 billion pieces per year.

High reliability versions of KEMET capacitors have shared in every important defense and aerospace effort of the past 60 years, from the first Telstar satellite and Apollo 11 to the Patriot Missile, International Space Station and Mars Pathfinder.

For more information, please visit us at [www.kemet.com](http://www.kemet.com) or call +864-963-6300.